

Guidelines for the fisheries and aquaculture sector on damage and needs assessments in emergencies



Guidelines for the fisheries and aquaculture sector on damage and needs assessments in emergencies

Edited by

David Brown

Fisheries and Aquaculture Officer
Policy, Economics and Institutions Branch
FAO Fisheries and Aquaculture Department
Rome, Italy

Florence Poulain

Fisheries and Aquaculture Officer
Policy, Economics and Institutions Branch
FAO Fisheries and Aquaculture Department
Rome, Italy

The designations employed and the presentation of material in this information product do not imply the expression of any opinion whatsoever on the part of the Food and Agriculture Organization of the United Nations (FAO) concerning the legal or development status of any country, territory, city or area or of its authorities, or concerning the delimitation of its frontiers or boundaries. The mention of specific companies or products of manufacturers, whether or not these have been patented, does not imply that these have been endorsed or recommended by FAO in preference to others of a similar nature that are not mentioned.

The views expressed in this information product are those of the author(s) and do not necessarily reflect the views or policies of FAO.

ISBN 978-92-5-107914-0 (print)
E-ISBN 978-92-5-107915-7 (PDF)

© FAO, 2013

FAO encourages the use, reproduction and dissemination of material in this information product. Except where otherwise indicated, material may be copied, downloaded and printed for private study, research and teaching purposes, or for use in non-commercial products or services, provided that appropriate acknowledgement of FAO as the source and copyright holder is given and that FAO's endorsement of users' views, products or services is not implied in any way.

All requests for translation and adaptation rights, and for resale and other commercial use rights should be made via www.fao.org/contact-us/licence-request or addressed to copyright@fao.org.

FAO information products are available on the FAO website (www.fao.org/publications) and can be purchased through publications-sales@fao.org.

Preface

In the last few decades, natural disasters have become more frequent and increasingly destructive. Populations depending on fisheries and aquaculture for their livelihoods are threatened not only by natural hazards but also by human-induced events and other developments beyond their control. Most small-scale fishers and fish workers live in developing countries, and they often face a multitude of problems that increase their vulnerability to hazards, such as pollution, environmental degradation, overexploitation of resources, high levels of accidents at sea and conflicts with industrial fishing operations. Many coastal communities are also particularly vulnerable to hazards resulting from poverty and food insecurity.

The particular characteristics of the fisheries sector and the livelihood context of small-scale fishers and fish farmers and their communities need to be clearly understood in order to be able to provide adequate disaster response in an emergency situation. An assessment of disaster impact is essential, not only for supporting the decision-making process before and during the immediate relief efforts, but also to set the basis for longer-term recovery planning.

Support to countries and to partners in response to disasters and to emergencies is becoming a greater part of the work of international agencies. In order to improve these responses, the international community has been developing new approaches to disaster preparedness. The “cluster approach”, adopted by the Inter-Agency Standing Committee (IASC) in 2006, is now used as the main mechanism to ensure effective, coordinated and time-critical emergency response. Within the cluster approach, FAO has been designated as the cluster lead of the Agriculture Sector/Cluster, which includes fisheries and aquaculture.

A steering group of key fisheries and aquaculture sector stakeholders was formed to develop guidelines and best practice standards, and vulnerability analysis tools for the cluster. The steering group included JICA (Shunji Sugiyama), FAO (David Brown, Florence Poulain and Simon FungeSmith), WorldFish Center (Eddie Allison and Mike Phillips), Network of Aquaculture Centres in Asia (NACA)(Sena DeSilva), and Marc Nolting (GTZ now part of the GIZ). In addition, through consultation, the core group also drew on the experiences of other agencies and field-level practitioners as required. Additional significant inputs were provided by others including B. Cattermoul, Phillip Townsley and J. Campbell (IMM Ltd), and S.N. Siriwardena (Aquaculture), Robert Lee (Fishing Gear) and Ari Gudmundsson (Fishing Vessels).

These guidelines are aimed at those people who participate in post-disaster needs assessment at the country level. These may include line ministry staff, national and international UN staff, national and international consultants and staff of non-governmental organizations. The guidelines are based on a core document, which articulates the process and reporting requirements of post-disaster needs assessments. This core document is then supported by a series of technical annexes that provide specific guidance relating to different aspects of fisheries and aquaculture.

Brown, D. & Poulain, F. (eds). 2013
Guidelines for the fisheries and aquaculture sector on damage and needs assessments in emergencies. Rome, FAO. 114 pp.

Acknowledgements

Thanks are due to all those who provided inputs and the technical staff at FAO's headquarters and decentralized offices for their efforts and contribution to these guidelines. Thanks also go to Magda Morales, Tina Farmer, Marianne Guyonnet and Julian Plummer for their contribution to the final production of this publication. The preparation of this document was possible thanks to funds provided by the Netherlands and Sweden through the FMM FAO Multipartner Mechanism (FMM/GLO/003/MUL) and from Sweden and Norway through the project "The Agriculture Sector's contribution to the 2007 Appeal for Building Global Humanitarian Response Capacity" (OSRO /GLO/704/MUL).

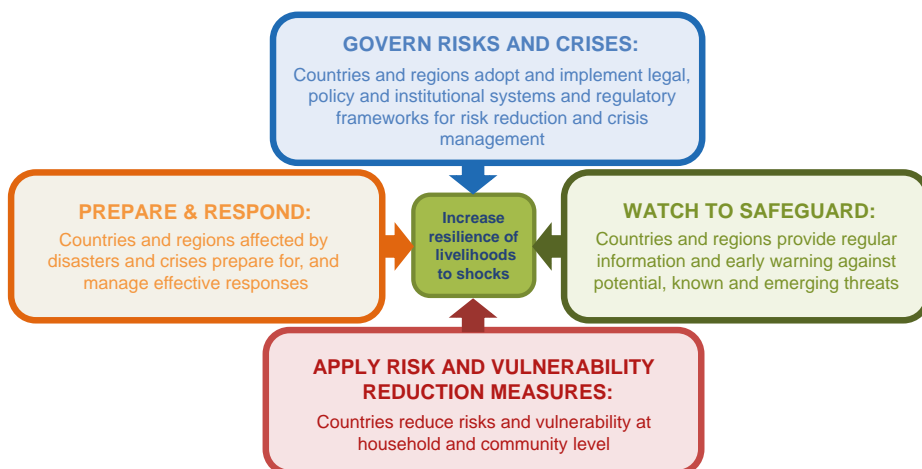

Resilient Livelihoods: Disaster Risk Reduction for Food and Nutrition Security - The four pillars of the FAO's Disaster Risk Reduction framework are aligned to support countries in implementing action plans under the Hyogo Framework for Action. FAO's strategic objective within this framework is to increase the resilience of livelihoods, including those of fishers and fish farmers, to threats and crises.

Contents

iii	Preface
v	Acknowledgements
	CHAPTER 1
1	Introduction
1	1.1 Purpose of the guidelines
1	1.2 Who are the guidelines for?
1	1.3 When are they used?
2	1.4 Structure of the guidelines
	CHAPTER 2
5	Disasters and the fisheries and aquaculture sector
5	2.1 Different types of disasters
6	2.2 Disasters and vulnerability
6	2.3 Fisheries, aquaculture and disasters
10	2.4 How fisheries and aquaculture can play a role in post-disaster recovery
11	2.5 The role of fisheries and aquaculture in post-disaster food and nutrition security
	CHAPTER 3
13	The disaster response context
13	3.1 Phases of disaster and disaster relief
16	3.2 The cluster approach
	CHAPTER 4
19	The fisheries and aquaculture sector policy framework
	CHAPTER 5
21	Disaster needs assessments
22	5.1 Coordinating with other damage needs assessments
23	5.2 Fisheries and aquaculture baseline
25	5.3 Initial impact appraisal
32	5.4 Detailed sector assessment
37	Annex 1 – Fisheries and aquaculture policy and management
37	A1.1 Introduction
37	A1.2 Effects of disasters on policies and management

39	A1.3 Threats to good policy and management processes in post-disaster situations
40	A1.4 Opportunities to improve fisheries and aquaculture policies
42	A1.5 Key information needs for damage needs assessment: policy and management
44	A1.6 Key resources
49	Annex 2 – Capture fisheries gear, vessels and engines
49	A2.1 Introduction
50	A2.2 Technical considerations for the damage and needs assessment (fishing gear, boats and engines)
71	Annex 3 – Landing sites, harbours and anchorages
71	A3.1 Introduction
72	A3.2 Damage assessment
77	Annex 4 – Aquaculture
77	A4.1 Introduction
77	A4.2 Overview of the damage assessment
79	A4.3 Technical specifications for damage needs assessment: aquaculture
88	A4.4 Recommendations in aquaculture
89	A4.5 Suggested format for detailed assessment
90	A4.6 Further recommendations in aquaculture
93	Annex 5 – Capture fisheries and aquaculture post-harvest, markets and processing
93	A5.1 Introduction
97	A5.2 Technical considerations for the damage and needs assessment
104	A5.3 Data collection, analysis and summary
106	A5.4 Key background reading
107	Annex 6 – Environment
107	A6.1 Introduction
107	A6.2 Potential effects of disasters on the environment
108	A6.3 Key requirements for identifying environmental management needs in post-disaster situations
110	A6.4 Technical specifications for damage needs assessment: environment
112	A6.5 Key resources

CHAPTER 1

Introduction

1.1 PURPOSE OF THE GUIDELINES

These guidelines are for use in post-emergency damage and needs assessment. The guidelines provide advice and a structure for assessing the requirements of relief and rehabilitation relating directly to fisheries and aquaculture.

The situation and exact timing of when the subsectoral assessment of fisheries and/or aquaculture is undertaken will vary. However, the process of identifying these sectoral requirements must be set in the holistic context that is the wider livelihoods of the affected communities. Therefore, it is critical that the assessment team endeavour to link up with other assessment missions.¹

1.2 WHO ARE THE GUIDELINES FOR?

These guidelines are intended for use by consultants or staff of organizations tasked with assessing the needs of the fisheries and aquaculture sector in post-disaster situations. It is assumed that those undertaking such assessments will be experienced professionals with knowledge of the sector but who may not necessarily have specific experience in working in post-disaster situations.

The guidelines aim to provide an adequate understanding of the key issues facing those carrying out an assessment in such conditions, while the technical annexes provide more detailed guidance on key technical considerations in the different areas that a post-disaster assessment for the sector should cover.

1.3 WHEN ARE THEY USED?

The timing of post-disaster assessments is not fixed and will depend on both the nature and scale of the disaster, the extent to which it has affected different sectors, and the scale and pace of the response. In principle, a number of key phases are identified, as shown in Figure 1.

¹ For an example of a more general assessment that incorporates wider livelihood aspects: FAO & ILO. 2009. The Livelihood Assessment Tool-kit – analysing and responding to the impacts of disasters on the livelihoods on people. Rome and Geneva. 191 pp. (also available at www.fao.org/fileadmin/templates/tc/tce/pdf/LAT_Brochure_LoRes.pdf).

FIGURE 1
Key phases in post-disaster assessments



In reality, the divisions between the phases are not always clear-cut and they tend to be closely interlinked and interdependent.

These guidelines are intended for use in the first three of these phases: the fisheries and aquaculture baseline; the initial impact appraisal; and the detailed sector assessment. The sector assessments will usually follow on from the initial appraisal and provide a more detailed understanding of the rehabilitation needs in the wake of the disaster. However, in some situations, the lines between the initial impact appraisal and the subsequent sector assessments may not be well defined, and practitioners in the field will be able to incorporate elements of the more detailed sector assessments into their initial impact appraisal work. Similarly, many elements of these guidelines will also be relevant when it comes to the third phase of the disaster response process – planning for long-term development.

The phasing of different forms of post-disaster assessment is discussed in more detail below.

1.4 STRUCTURE OF THE GUIDELINES

These guidelines are divided into two main sets of documents:

1. **General guidelines.** These provide an introduction to the work of conducting disaster needs assessments. They introduce the overall context of a disaster situation, paying particular attention to the structure of relief efforts and where a sector assessment of fisheries and aquaculture will fit in. These general guidelines also cover the generic, non-technical issues relating to disaster needs assessments that fisheries and aquaculture specialists will need to be aware of before they begin work.
2. **Detailed technical guidelines.** These annexes provide more detailed, technical guidelines organized under the key subsectors in fisheries and aquaculture, and they include checklists of key points that those carrying out a sector needs assessment should cover in their work.

1.4.1 General guidelines

The general guidelines are divided into three sections, which are explained below.

Section 2: Disasters and the fisheries and aquaculture sector – This section introduces the specific features of different types of disaster situations

and the particular issues affecting the fisheries and aquaculture sector in the wake of different disasters. It is made up of five subsections:

- different types of disasters;
- disasters and vulnerability;
- disasters, fisheries and aquaculture;
- how fisheries and aquaculture can play a role in post-disaster recovery;
- the role of fisheries and aquaculture in post-disaster food and nutrition security.

Section 3: The disaster response context – This section outlines some of the key factors that those undertaking a post-disaster assessment of the fisheries and aquaculture sector need to keep in mind to ensure that the work they do fits into the overall framework of response to a disaster situation. It is divided into three subsections:

- understanding the phases of disaster response;
- the cluster approach to disaster response;
- linking sectoral assessments to broader disaster response mechanisms.

Section 4: Undertaking a disaster needs assessments – an overview – This section briefly outlines the key types of disaster needs assessment and some of the key considerations relevant to each of these types of assessment. It then provides an overview of the three stages of assessment:

1. **Fisheries and aquaculture baseline information** – This subsection provides some essential guidance on collecting and collating baseline information as a starting point in conducting post-disaster assessments.
2. **Initial impact appraisal** – This subsection focuses on those aspects of conducting a post-disaster needs assessment in fisheries and aquaculture that are specific to the initial assessment of damage and response needs. It is divided into the following subsections:
 - What does the initial impact appraisal aim to achieve?
 - When is it done?
 - What information should it contain?
3. **Detailed sector assessment** – This section provides guidance on the detailed sector assessment for fisheries and aquaculture, and it includes the following sections:
 - What does the Sectoral Assessment aim to achieve?
 - When is it done?
 - What information should it contain?

1.4.2 Detailed technical guidelines

The general guidelines are supported by annexes containing more detailed guidance, including checklists and reporting frameworks for key information.

The annexes are:

Annex 1: Fisheries and aquaculture policies and management

This looks at the effects of disasters on policies and management, the threats to good policy that might emerge from disaster situations, opportunities for improved sector policies and the policy framework in which these should occur.

Annex 2: Capture fisheries

This covers in detail the technical considerations that are required in order to undertake an assessment of marine or freshwater capture fisheries operations and their rehabilitation and reconstruction needs.

Annex 3: Landing sites

This annex looks at potential damage to fisheries landing sites as a result of a disaster and provides guidance on technical considerations for their rehabilitation and reconstruction.

Annex 4: Aquaculture

Here, the specific technical requirements of the aquaculture subsector in a post-disaster situation are explained, including coverage of different scales and types of aquaculture operation.

Annex 5: Post-harvest

This annex looks at the specific requirements of the post-harvest sector for both capture fisheries and aquaculture.

Annex 6: Environment

This annex looks at the state of the environment and how that may change as a result of a disaster.

Additional guidance materials may be developed to further support practitioners to undertake damage and needs assessment for the fisheries and aquaculture sector.

CHAPTER 2

Disasters and the fisheries and aquaculture sector

2.1 DIFFERENT TYPES OF DISASTERS

A disaster is a serious disruption in the life of a community or society that causes extended losses and requires external assistance. Disaster risk is a function of a hazard, and of the vulnerability and exposure of the community or society to the hazard.

Disasters can be classified in three categories:

- **Natural disasters:** These include disasters originating from hydrometeorological hazards (floods, waves and surges, storms, droughts, etc.), geological hazards (earthquakes, volcanic eruptions, etc.) and biological hazards (epidemics, insect infestations, etc.).
- **Technological disasters:** These are defined as disasters directly related to human activity and that are the result of failure of a technology or of management, or of an accident involving machinery or infrastructure.
- **Complex emergencies:** These are humanitarian crises resulting from military conflict or civil strife in which external assistance is needed in order to help populations deal with the consequences.²

Within these three broad categories, an important distinction regards the relative suddenness of an emergency. The types of needs assessment covered in these guidelines are particularly relevant for what are termed “**sudden onset**” emergencies. These are disasters (whether natural, technological or complex) that result in a sudden and dramatic change in conditions and require outside intervention to assist affected populations. They are distinguished from “**slow onset**” emergencies where the impacts of a particular set of conditions, such as drought or disease, may slowly accumulate until they generate an emergency situation.

² For more in-depth background discussion on disasters and fisheries and aquaculture: Westlund, L., Poulain, F., Båge, H. & van Anrooy, R. 2007. *Disaster response and risk management in the fisheries sector*. FAO Fisheries Technical Paper No. 479. Rome, FAO. 56 pp. (also available at www.fao.org/docrep/010/a1217e/a1217e00.htm).

2.2 DISASTERS AND VULNERABILITY

Three key factors combine to produce a disaster:

1. **Hazard:** This is the event, such as an earthquake or a cyclone (**natural hazards**), an oil spill or bridge collapse (**technological hazards**), or an armed conflict that has the **potential** for creating a disaster. It is important to recognize that these events, in themselves, do not necessarily constitute a disaster.
2. **Exposure:** This means the extent to which a particular hazard affects different populations. The disastrous impact of a particular hazard will depend on where and when it happens, its severity and magnitude, and the extent to which people and property are found in the area where a hazard occurs and in locations that are affected by it.
3. **Vulnerability:** This is the extent to which the people exposed to a particular hazard are able to cope with its effects.

In undertaking a disaster needs assessment for the fisheries and aquaculture sector, a key first step is to define:

- the hazard;
- the exposure of people in the sector to that hazard;
- the relative vulnerability of different stakeholders in the sector to the effects of that hazard.

Vulnerability is defined as “a condition resulting from physical, social, economic and environmental factors or processes, which increases the susceptibility of a community to the impact of a hazard”.³ Poverty is a main cause of vulnerability in many parts of the world, and there is a clear link between disaster risk and development. In many fisheries and aquaculture communities, the core elements of vulnerability (poverty and exposure) are common characteristics.

2.3 FISHERIES, AQUACULTURE AND DISASTERS

In the wake of any disaster that affects the fisheries and aquaculture sector, those carrying out a post-disaster needs assessment will be presented with an extremely complex range of impacts that potentially affect the lives and livelihoods of a large and diverse set of stakeholders. Understanding and differentiating between these impacts on different groups and their activities will be extremely challenging.

When approaching this task, it is important to recognize that the impacts of a disaster cannot be reduced to a set of material losses that need to be replaced.

³ Asian Disaster Reduction Centre. 2005. Total disaster risk management – good practices 2005 [online]. [Cited 16 May 2013]. www.adrc.asia/publications/TDRM2005/TDRM_Good_Practices/GP2005_e.html

Disasters affect the entire set of interrelated activities and relationships on which people depend. Material losses – to equipment, productive assets, housing, and infrastructure – represent one part of these. It is often the relationships between different elements in people’s livelihoods that are crucial, and replacing single elements will often not necessarily enable the victims of a disaster to re-establish their capacity to deal with post-disaster conditions and restore a sustainable and viable livelihood for themselves and their families. The disaster event, its impact and the response form an intricate pattern of causes and effects influencing the livelihoods of the affected coastal communities in both the short term and long term. Figure 2 gives a schematic overview of how disasters can affect coastal communities.⁴

FIGURE 2 The impacts of disasters on coastal communities

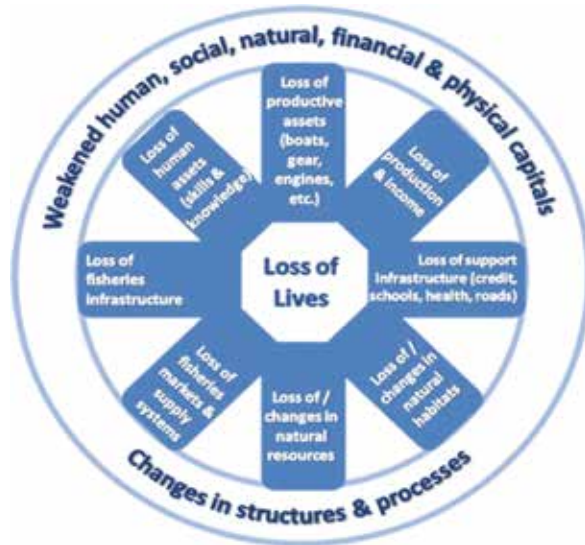

In seeking to understand the impacts of a disaster on the people who depend, in part or entirely, on the fisheries and aquaculture sector, those undertaking an assessment of the sector have to understand the relationships between different elements in people’s livelihoods in a holistic way. This is a crucial first step in understanding which of the key elements (including the replacement of material losses) should be replaced in order to re-establish both the livelihood capacity of the individuals involved in the sector and the productive capacity of the sector as a whole.

⁴ For further information on disaster risks and vulnerability in the fisheries sector: Westlund, L., Poulain, F., Båge, H. & van Anrooy, R. 2007. *Disaster response and risk management in the fisheries sector*. FAO Fisheries Technical Paper No. 479. Rome, FAO. 56 pp. (also available at www.fao.org/docrep/010/a1217e/a1217e00.htm).

FIGURE 3 Key steps in understanding the effects of a disaster on people

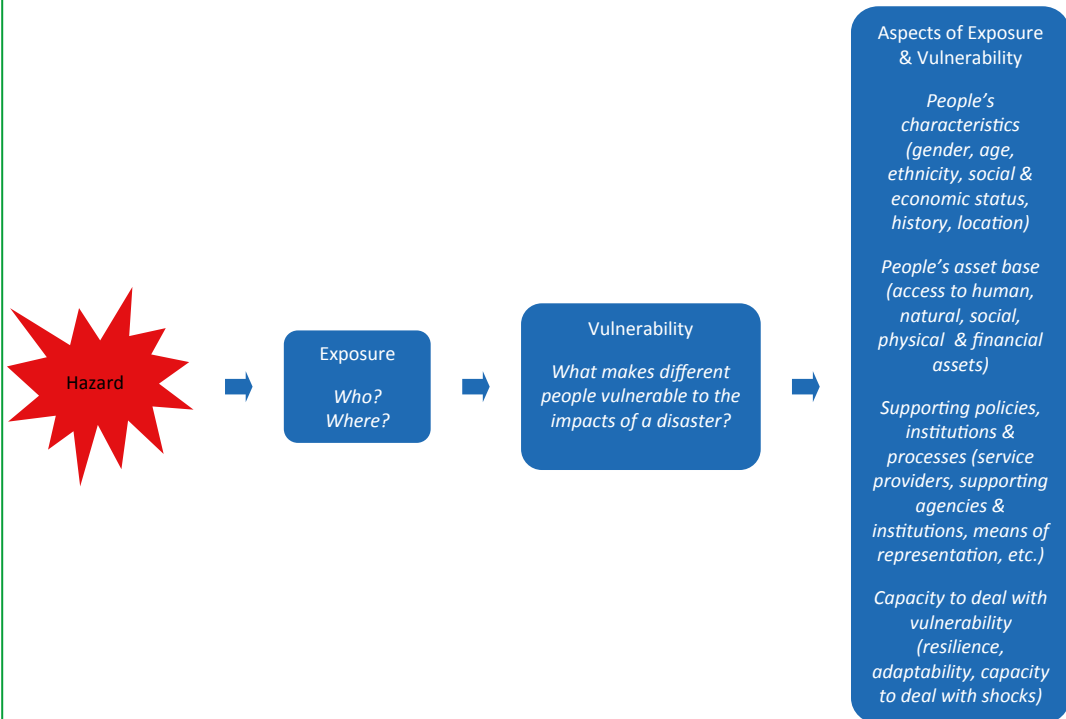

Three key steps are involved in achieving this holistic understanding of the effects on the people within the sector of a particular disaster. These are shown in Figure 3.

Understanding the **exposure** and **vulnerability** of different people involved in the sector to a particular hazard will often rely on existing background or baseline information about the different actors in the sector. The mapping of impacts of a particular disaster that is often carried out in the early stages of the immediate relief effort will generally help to establish who the potentially affected people in the sector are and **where** they are located. Other existing studies may help those carrying out a disaster needs assessment to understand more about how different groups active in the sector may be more or less vulnerable to the effects of a disaster.

When it comes to designing in detail the process of rehabilitation and reconstruction of the sector, a detailed understanding of the different aspects of the livelihoods of different stakeholder groups in the fisheries and aquaculture sectors is critical. Different stakeholders, defined not just by their activities in the sector but by **gender, age, ethnic group**, their **social and economic status** (Box 1), are likely to be exposed to different types of hazards in different ways. There will often also be very considerable differences between the levels of exposure of the marine capture fisheries subsector compared with aquaculture.

Similarly, different stakeholder groups within subsectors will also be exposed to the impacts of hazards in different ways. Understanding those stakeholders and types of sectoral activities that are most likely to have been affected by a particular hazard is an important first step in conducting any disaster needs assessment.

TABLE 1
How fisheries and aquaculture contribute to disaster relief and to rehabilitation, reconstruction and development

Disaster relief	Rehabilitation and reconstruction		Sustainable development
<ul style="list-style-type: none"> • Readily available fish provides immediate protein-rich food plus vitamins, minerals and fatty acids. • Equipment and skills for relief work: Fishing boats and canoes can be used to transport valuable belongings to safe places and relief supplies to inaccessible areas • Fast start-up – Many small-scale fisheries activities require very small amounts of upfront capital investment and can be re-started rapidly in the aftermath of a disaster. This can support the emergency and relief efforts and set a positive tone for recovery. 	<ul style="list-style-type: none"> • Underpinning the livelihoods of millions of rural people: More than 3 billion people depend upon fish for at least 20 percent of their animal protein. It was estimated in 2010 that 54.8 million people were directly engaged (part-time or full-time) in the production of fish in coastal or inland waters, with more than 16.6 million of these involved in aquaculture.¹ For each person involved in fishing and fish farming, there are about three people involved in post-harvest and ancillary activities – many of them women. When people employed in the sector are combined with their dependents, between 660 million and 820 million people are dependent on the sector.¹ • Concentrating revenues into localized areas and acting as a multiplier for localized economic diversification. The geographical concentration of fisheries and aquaculture harvesting can lead to a significant stimulus to growth on a local basis. This often results in economic activity clustering around such hubs, the development of market systems and supporting institutions, and investment in local infrastructure. • Generating revenues for national government for growth to be achieved by managing fisheries for sustainable use and capturing rents through royalties and taxes. Such rents can be reinvested in society for wider development and poverty reduction strategies if the political economy allows. The traded value of fisheries globally is in the order of US\$86 billion. • Providing a safety net for people displaced from other sectors or displaced from the urban environment during economic crises or during conflicts. In such situations, the low entry costs and skills requirements (for basic fishing at least) to open-access fisheries provide people with an occupation of last resort. Similarly, the dispersed landing sites and the availability of small quantities of fish, make it an opportunity for very small-scale processing and trading (often for women). • Retaining a stock of future benefits that are not realized at present but may become significant drivers of growth in the future (such as aquatic resources for pharmaceuticals and other potential ecosystem services). 		

¹ FAO. 2012. *The State of the World Fisheries and Aquaculture 2012*. Rome. 209 pp.

BOX 1

Exposure, vulnerability and the impacts of disasters – understanding gender-based differences

Men and women experience different levels of exposure and vulnerability to the effects of disasters because of their roles (in the household, in the community and in production), their access to resources and the ways they participate in decision-making and local institutions. For example, it is estimated that up to 80 percent of the victims of the 2004 Asian tsunami were women. In the case of fishing communities in India and Sri Lanka, the timing of the disaster combined with women's role in fish marketing meant that many women fish-vendors were on the beach when the disaster struck. This in turn had important implications for the process of recovery from the disaster for the artisanal fisheries sector. Similarly, the differences in the social position of women and men can mean that their access to relief and recovery mechanisms may be very different, and this can in turn lead to divergences in the longer-term impact on them as a result of a disaster.

Understanding and appreciating how these differences affect the vulnerability and exposure of women and men is a key step in assessing the impacts of a disaster. Critically, every effort should be made to disaggregate information collected in any disaster needs assessment by gender and to consider how the needs of women and men may differ.

Similar attention will often be required for other key factors that differentiate those affected by a disaster, such as age or ethnic group.

2.4 HOW FISHERIES AND AQUACULTURE CAN PLAY A ROLE IN POST-DISASTER RECOVERY

In disaster situations, the numbers of people affected can be large and will often include people involved in many different sectors of economic activity. Especially in large-scale disasters, the demands on relief mechanisms will be huge and there will often be a need to prioritize relief efforts to ensure that those most in need, and most seriously affected by the disaster, are assisted first.

However, once these urgent needs are dealt with, prioritizing rapid efforts to rehabilitate the fisheries and aquaculture sector can make an important contribution to the overall disaster-relief process. Fisheries produce high quality food that can usually be accessed relatively quickly in the wake of a disaster. By contrast, agricultural production may require a longer period of rehabilitation before it can begin to produce sustainable local food supplies.

Table 1 provides an overview of some of the key ways in which fisheries and aquaculture can contribute to immediate relief in the wake of a disaster and to the longer-term process of rehabilitation, reconstruction and development that follows.

2.5 THE ROLE OF FISHERIES AND AQUACULTURE IN POST-DISASTER FOOD AND NUTRITION SECURITY

Fisheries and aquaculture play an important role in food and nutrition security in disasters that affect communities where fishers and fish farmers are an important part of the community. **First**, those communities are likely to have fish and fisheries products as an important part of their pre-disaster diet and will therefore depend upon them in post-disaster situations. **Second**, fish and fisheries products have high levels of nutrients and essential oils, which can be particularly important to people in a post-disaster situation – especially young children, the very old, pregnant women and HIV/AIDS affected people. **Third**, the fisheries sector is one where fish harvests can be resumed fairly quickly, thereby enhancing local food supplies at a time when food may be in limited supply. **Fourth**, preserved and locally stored fish can be a readily available source of food and nutrition immediately after a disaster.

Immediate emergency response activities might include the following:

- Assess early warning and nutrition surveillance data to understand baseline pre-disaster national and local food and nutrition food security and associated outline data (including household food insecurity, prevalence of HIV/AIDS, crude mortality rate, under-five crude mortality rates, epidemic of diseases that might affect recovery, high prevalence of respiratory or diarrhoeal diseases, and high prevalence of pre-existing malnutrition).
- Assess the post-disaster changes to food and nutrition security against appropriate baseline and cause of changes.
- Assess the potential of current stocks of preserved and processed fish and fisheries products, and immediate potential supplies of farmed and wild-caught fish from national sources to feed into emergency food supplies.
- Assess the policy environment supporting or inhibiting the use of fish in food aid.
- Assess the potential of using fish and fisheries products in emergency support initiatives such as food for work, as food rations and through coupons for fish.
- Inform other workers in the emergency response of the potential role of fish in food and nutrition security in the disaster, and on the availability of fish for food aid post-disaster.
- Recognize the importance of, and assess the need for, the role of fish in food and nutrition for particularly vulnerable stakeholders such as young children, the very old, pregnant women and HIV/AIDS affected people.
- Build back better, with particular attention to the responsible management of fish stocks, in order to ensure the continuing role of fish and fisheries products in future food and nutrition security.

CHAPTER 3

The disaster response context

3.1 PHASES OF DISASTER AND DISASTER RELIEF

The different types of post-disaster needs assessment correspond closely to the overall phases that are commonly identified in post-disaster response. For each of these phases, in most emergencies, different mechanisms will be in place to deal with the specific needs of that phase. The relationships between these phases, the common response mechanisms and the various types of assessments that feed into those mechanisms are shown in Figure 4.

FIGURE 4 Relationships between disaster phases, response mechanisms and assessments

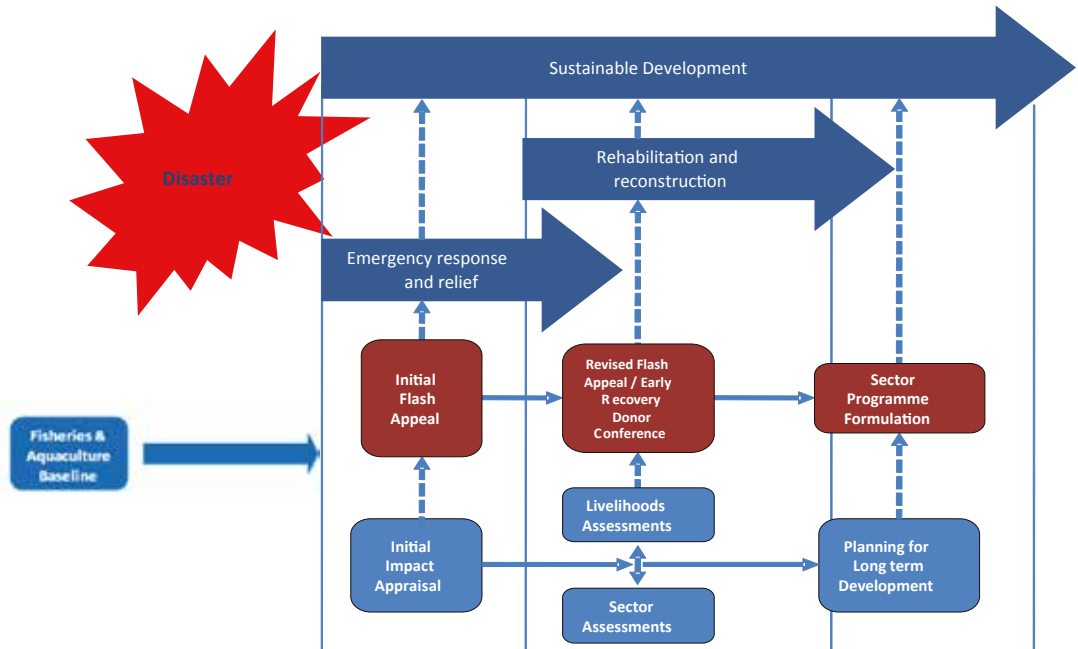

Understanding the relationships illustrated in Figure 4 is important for the assessment teams. The teams will need to tailor their activities to the specific needs of the phase of disaster response they are dealing with and the mechanisms in place at the time.

The phases outlined in Figure 4 relate specifically to **sudden onset** emergencies; for example, catastrophic natural disasters such as floods, cyclones or earthquakes, or major technological disasters such as oil spills or major contamination events. In the case of emergencies that are **not** rapid onset or complex emergencies, the divisions between the different phases may be less clearly defined.

3.1.1 Emergency response and relief

This phase is normally defined as covering the first seven days in the wake of a sudden onset disaster. It is a phase that is characterized by the inability of the affected population to sustain itself independently. At this time, populations require immediate assistance and establishment of minimum conditions for survival (Box 2). The primary focus of the response mechanisms is:

1. to provide immediate relief to the population affected by the disaster;
2. to minimize vulnerability to further catastrophes;
3. to ensure access to basic needs of health, water, food, shelter, sanitation, livelihoods and protection for the affected population.

The last of these points is of particular importance in relation to fisheries and aquaculture. An initial impact appraisal of the damage to the fisheries and aquaculture sector can help ensure that the sector is quickly able to restore its potential contribution to local food supplies and to livelihoods. Compared with other sectors within the agriculture cluster, capture fisheries can, with the proper support (and depending on the scale of damage to aquatic ecosystems), recover relatively quickly and begin to contribute to the overall relief and reconstruction process.

BOX 2

Terminology for the phases of post-disaster relief efforts

In some cases, the phases in post-disaster response may be defined slightly differently compared with those used in these guidelines. **Relief response** refers to efforts during or immediately after a disaster to preserve life and provide basic subsistence needs. **Early recovery** is used to describe a multidimensional process, carried out in parallel with relief response, to establish “...self-sustaining, locally-owned, resilient processes for post-crisis recovery”. It thus represents a “bridge” between the phases referred to here as **emergency response and relief**, and **rehabilitation and reconstruction**. **Medium-term recovery** corresponds to rehabilitation and reconstruction as used in these guidelines.

While priority is given at this stage to satisfying the critical basic needs of food, water, health, shelter and sanitation, the importance of immediately identifying the requirements for restoring people's livelihoods is increasingly being recognized. The recovery of affected populations in the wake of a disaster is dependent not only on their access to these basic needs but also on their ability to return to a "normal" livelihood and take responsibility for their own recovery as quickly as possible. Without this, they will remain highly vulnerable to future hazards.

3.1.2 Rehabilitation and reconstruction

This phase covers the period after the immediate relief efforts and focuses more widely on supporting affected populations in returning, as far as possible, to the conditions that they lived in prior to the onset of the disaster. It is during this time that the foundations for building back better should be laid.

The exact timing of this phase will depend considerably on the nature, scale and severity of the disaster in question. After major catastrophes, such as the 2004 Indian Ocean tsunami or the 2006 Pakistan earthquake, the period when immediate relief takes priority may last longer simply because of the scale, the numbers of people involved and the difficulties in reaching them.

Similarly, defining when the rehabilitation and reconstruction phase ends and longer-term development processes can be resumed is extremely variable and difficult to determine. Major disasters may require years of concerted efforts before affected communities and their members can be regarded as having returned to "normal". Some impacts of such disasters may never be completely overcome. On the other hand, more limited emergencies may produce impacts that can be overcome in a relatively short time and with more limited reconstruction efforts.

3.1.3 Long-term development

Generally, as the immediate impacts of a disaster are overcome and reconstruction efforts proceed, it will become progressively more important to ensure that the actions taken to support reconstruction are coordinated with wider development plans, processes and policy.

In a positive sense, the aftermath of a disaster may present important opportunities in terms of longer-term development. These can be generated by:

- the concentration of resources and agencies in a relatively limited area affected by the disaster;
- the reorganization of traditional arrangements, institutions and social relations as a result of the disaster;
- the recognition of weaknesses and vulnerabilities in existing production systems that the disaster has highlighted;

Recognizing and taking advantage of these opportunities from early in the rehabilitation and reconstruction phase can hasten the progression towards the longer-term development phase.

3.2 THE CLUSTER APPROACH

The cluster approach for international emergency response was introduced to strengthen predictability, response capacity, coordination and accountability by building partnerships in key sectors of humanitarian response, and by formalizing the lead role of particular agencies and/or organizations in each of these sectors.

The responsibilities of the leading agencies in each cluster are defined as:

- setting overall policy for disaster response in that particular sector;
- defining standards and best practice;
- building response capacity including training, “surge” capacity standby rosters and stockpiles of relevant materials;
- operation support through capacity assessment, emergency preparedness, access to technical expertise, advocacy and resource mobilization.

As the agency leading the cluster on agriculture, FAO is responsible for these four key areas in relation to responses in the agriculture sector to emergencies. The agriculture cluster includes fisheries and aquaculture, as well as agriculture, livestock and forestry.

Table 2 reviews the clusters currently established and the agencies leading each of these clusters.

TABLE 2
Summary of the cluster approach for international emergency response

Cluster / sector	Global lead / convener	Cluster / sector	Global lead / convener
Emergency shelter	United Nations High Commissioner for Refugees (UNHCR) (conflict internally displaced persons [IDPs]) International Federation of the Red Cross and Red Crescent Societies (IFRC) (“convener” in disaster situations)	Early Recovery	United Nations Development Programmes (UNDP)
Health	World Health Organization (WHO)	Camp Coordination / Camp Management (CCCM)	UNHCR (displaced persons [DPs] from conflict) International Organization for Migration (IOM) (disaster situations)

(cont.)

Cluster / sector	Global lead / convener	Cluster / sector	Global lead / convener
Nutrition	United Nations Children's Fund (UNICEF)	Protection	UNHCR (global cluster lead, field-level lead in conflict) UNHCR, Office of the High Commissioner for Human Rights (OHCHR), UNICEF (decide on leadership for field-level in disaster situations)
Water, sanitation and hygiene (WASH)	UNICEF	Emergency Telecoms	Office for the Coordination of Humanitarian Affairs (OCHA) (process owner) World Food Programme (WFP) (security telecoms) UNICEF (data telecoms)
Education	UNICEF Save the Children Alliance	Logistics	WFP
Agriculture (including fisheries and aquaculture)	FAO		
Cross-cutting issue "clusters"			
Age	Help Age International	Gender	United Nations Population Fund (UNFPA), WHO (Co-Chairs)
Environment	United Nations Environment Programme (UNEP)	HIV/AIDS	Joint United Nations Programme on HIV/AIDS (UNAIDS)

CHAPTER 4

The fisheries and aquaculture sector policy framework

The implementation of all disaster responses within the fisheries and aquaculture sector needs to be carried out within the broad and evolving sector policy framework. This consists of a number of different components as outlined below:

CODE OF CONDUCT FOR RESPONSIBLE FISHERIES

The Code of Conduct for Responsible Fisheries (the Code) was developed by representatives from members of FAO, intergovernmental organizations, the fishing industry and non-governmental organizations (NGOs). The Code represents a global consensus and voluntary agreement on a wide range of fisheries and aquaculture issues. It represents internationally recognized standards for the development and regulation of fisheries and aquaculture. The Code therefore provides an important framework of recommended practice to guide response, recovery and rehabilitation in the wake of a disaster or emergency that has affected the sector.

ECOSYSTEM APPROACH TO FISHERIES AND AQUACULTURE

The management and development of the fisheries and aquaculture sector also needs to adopt an ecosystem approach. This strives to balance diverse societal objectives by taking into account the knowledge and uncertainties about biotic, abiotic and human components of ecosystems and their interactions and by applying an integrated approach to fisheries within ecologically meaningful boundaries. This is particularly important given the complex nature of the livelihood strategies of fishing and aquaculture households and communities where a diversity of livelihood activities is the norm. Such an ecosystem approach needs to be fully incorporated into any disaster response, thus adopting a more holistic approach that reinforces the need for cross-sectoral coordination.

DISASTER RISK MANAGEMENT

Reducing and managing the effects of hazards and disasters in the fisheries and aquaculture sector can be achieved through disaster risk management (DRM). Disaster risk management goes beyond preparedness, prevention and mitigation, which form the core of disaster risk reduction, to incorporate emergency response, recovery and rehabilitation within a management

framework. It adopts a much more comprehensive approach to hazards and disasters, and links these to better development processes into which DRM should be mainstreamed. The underlying framework for this is the Hyogo Framework for Action (HFA). The HFA outlines priorities for action, and offers guiding principles and practical means for achieving disaster resilience. Its goal is to reduce disaster losses substantially by building the resilience of nations and communities to disasters.

OIE/FAO ANIMAL HEALTH/DISEASE FRAMEWORKS

FAO, the World Organisation for Animal Health (OIE) and the World Health Organization (WHO) have established a long-term basis for international collaboration aimed at coordinating global activities to address health risks at human–animal–ecosystem interfaces. This is particularly important in the aquaculture sector where initiatives need to be taken to ensure that growing (and recovering) aquaculture industries will be adequately serviced with aquatic animal health professionals (veterinarians or others) in the future. Post-disaster needs assessment initiatives should aim to: address needs from farm level to government level; address infrastructure, education and legislative issues; and involve key stakeholders from governments, academia and the private sector in the process.

CLIMATE CHANGE ADAPTATION

Disasters in the fisheries and aquaculture sector are likely to be more frequent and more intensive in the future as a result of climate change. Adaptation to climate change effects should be fully incorporated into disaster response mechanisms and into wider sector development processes. Guidance for this is covered by the **United Nations Framework Convention on Climate Change (UNFCCC)**.

CHAPTER 5

Disaster needs assessments

The fisheries and aquaculture damage and needs assessment guidelines set out a process of three interrelated elements: (i) a fisheries and aquaculture baseline; (ii) an initial impact appraisal for fisheries and aquaculture; and (iii) a detailed sector assessment for fisheries and aquaculture. Each element serves different but related functions in the assessment process. Each element may also have different targets in terms of funding mechanisms and may be executed by different people, as indicated in the Table 3.

TABLE 3
Damage and needs assessment guidelines: elements and functions

Features	Fisheries and aquaculture baseline	Initial impact appraisal – fisheries and aquaculture	Detailed fisheries and aquaculture sector assessment (DeFASA)
Purpose	To provide a good picture of “normal” fisheries and aquaculture patterns in areas at risk from natural hazards.	To provide the early disaster response appeals with a set of figures that define the overall requirements of the fisheries and aquaculture sectors for rehabilitation and reconstruction so that the process of mobilizing funding can begin.	To provide a thorough assessment of the impact of disaster on livelihoods and identify opportunities and capacities and assistance needs for recovery at household, community, and local economy levels.
Timing	Pre-disaster (ongoing).	Usually within one week of the disaster. Will take about one week to complete.	Started within seven weeks of the disaster. About one month.
Access to information	Full access.	Limited – There is not time to visit all locations and talk to full range of informants. OR – security and/or safety limit movement and access to people.	Possible to visit enough locations and interview a full range of informants.
Typical Information	Published statistics; maps showing areas at risk and administrative boundaries; reports on fisheries and aquaculture; fisheries and aquaculture policy and strategy documents; participatory appraisals; past development project reports.	Secondary information, local fisheries and aquaculture information (e.g. types of activities, numbers of fishers), NGOs, government, affected population/household visits (small sample if possible).	Secondary information, full range of informants.
Importance of Assumptions	Medium – It is not possible to fully predict the nature and scale of a disaster or how people will respond.	High – Insufficient time to gather full information. Must make assumptions based on previous experience.	Low – Sufficient time to interview full range of informants.
Type of assessment team	National fisheries staff, NGOs, research groups and staff from departments responsible for disaster management.	Experienced fisheries and aquaculture generalist, with previous exposure to this type of emergency.	Fisheries and aquaculture generalist, likely to be supported by specialists.

5.1 COORDINATING WITH OTHER DAMAGE NEEDS ASSESSMENTS

Ideally, the fisheries and aquaculture sector assessments should be carried out in close collaboration and coordination with other damage and needs assessments. The exact configuration of these assessments is likely to vary depending on the agencies present on the ground and the timing of their involvement.

Some of the most common assessment processes that those conducting a fisheries and aquaculture damage needs assessment need to be aware of will include:

1. **Joint assessment:** This is used to describe any collaborative efforts involving different agencies and institutions to carry out a post-disaster needs assessment. In Thailand, after the 2004 tsunami, FAO carried out a joint assessment of fisheries and aquaculture together with the Thai Ministry of Agriculture and Cooperatives. In 2006, in Myanmar, after Cyclone Nargis, a joint assessment was carried out that involved the Government of Myanmar, the Association of Southeast Asian Nations (ASEAN), all the key UN Agencies and representatives of NGOs. In the future, this latter example is likely to become more frequent in the wake of major disasters.
2. **Livelihoods assessment:** This is a relatively new approach to analysing post-disaster needs that involves taking a more holistic, cross-sectoral view of how people's livelihoods have been affected by a disaster and how to support rehabilitation and reconstruction across sectors rather than focus on specific sectors in isolation. For more about linkages between the detailed assessment of fisheries and aquaculture with livelihoods assessments, see Box 3.
3. **Other sector assessments:** At the same time as the fisheries and aquaculture specialists are conducting their detailed assessment of the sector, other specialists are likely to be carrying out assessments of damage caused by the disaster in other sectors. Whatever the level of formal coordination that is taking place between these assessments, collaboration, either in the field or in terms of comparing results and cross-checking information where there are overlaps between sectors, is important. In **capture fisheries**, specialists looking at damage in the subsector will need to understand the results of **environmental assessments** (especially in relation to waterbodies, wetlands, rivers and coastal waters) and assessments of damage to **infrastructure and transport** that may play a critical role in ensuring that fish can be marketed and that input supplies are accessible. In aquaculture, it will be particularly important to take into account the results of the overall assessment of damage in the agriculture sector and the water sector.

BOX 3

Linking sector assessments with livelihood assessments

Fisheries and aquaculture will usually represent just **one part** of the livelihoods of people active in the sector, and only rehabilitating their sectoral activities may fail to address many other critical needs. Similarly, detailed information about the fisheries and aquaculture requirements will make a key contribution to an effective livelihoods assessment in communities where fisheries and aquaculture are important activities. Incorporating the sector assessment as closely as possible into the broader livelihoods assessment will ensure that fisheries and aquaculture will be given the correct degree of emphasis in relation with other livelihood needs. In particular, it will ensure that the interdependency of different livelihood elements is taken into account. For example, understanding the seasonal patterns of different household livelihood activities in “fishing” households is important. This will help teams to understand what activities should be the focus of rehabilitation efforts in the immediate wake of a disaster. A focus on fisheries may turn out not to be a priority for all fishing households at that particular time of year as other activities normally take precedence. Similarly, effective rehabilitation of the fisheries activities of fishing households may be dependent on the reactivation of other household activities that support fisheries, such as fish processing and marketing by family members, or even completely different activities outside the sector that will play a supporting role if fishing activities are to be reactivated sustainably.

4. **The potential role of fisheries in food and nutrition security:** The fisheries and aquaculture sector may well be in need of considerable support and help during and after a disaster, but it can also play a vital role in food and nutrition security that needs to be explored with other agencies involved in disaster recovery and rehabilitation.

5.2 FISHERIES AND AQUACULTURE BASELINE

5.2.1 *What does it aim to achieve*

The baseline information is designed to provide a good picture of “normal” fisheries and aquaculture patterns in areas at risk from natural hazards. The picture of a pre-disaster situation is fundamentally important in the process of assessing damage and needs.

Ideally, this would be undertaken prior to a disaster as a part of a nation’s disaster preparedness strategy. Where this has been possible, it provides a “head start” for post-disaster assessment and so enhances the effectiveness of the initial impact appraisal and the detailed sector assessment. In the event that the initial impact appraisal is not possible **before** the flash appeals are launched, the baseline can also provide grounds for extrapolation of likely impacts to inform these appeals.

The fisheries and aquaculture baseline is intended to meet the following specific objectives:

- Facilitating comparison of the fisheries and aquaculture activities and outcomes for families, communities and local economies before and after a disaster.
- Providing a robust basis for making estimates of the impact of disasters on fisheries and aquaculture, which can feed into flash appeals.
- Giving a “head start” to and providing a basis for immediate post-disaster assessments including the initial impact appraisal.
- Providing a basis for the more in-depth detailed sector assessment.

Collecting, updating and analysing livelihood baseline information is an integral part of the general disaster preparedness function. However, while it is preferable to prepare livelihoods baseline information before a disaster strikes, this may not always be possible. When disasters occur in unexpected places, baseline information must be compiled on the spot, in a much more summary way.

5.2.2 Types of information

The following types of information are normally necessary for creating a livelihood baseline:

- published statistics covering areas such as demography, employment, land sizes, licensed fishers and fish farmers, fishing seasons;
- maps showing the geographical areas at risk with delineation of important administrative boundaries;
- reports and studies relating to fisheries and aquaculture livelihoods and hazards in the areas at risk; this covers a wide spectrum including official government reports, research and academic studies, UN, regional and World Bank reports, studies by international and national NGOs.
- baseline and/or livelihoods information from past and current fisheries and aquaculture development projects
- information derived from participatory rural appraisal (PRA) exercises facilitated by the baseline team.

5.2.3 Institutional partnerships

Preparing the fisheries and aquaculture baseline is part of the general disaster preparedness process, and it should be integrated into it whenever possible. Therefore, the teams will need to liaise with the government departments that are mandated to cope with disaster preparedness and response. Similarly, much of the information required for a good baseline is important in the day-to-day management of fisheries and aquaculture.

Ownership of the baseline information should remain, as far as possible, with the government (national and local).

5.2.4 Time frame

The time taken to compile a baseline in a particular country will depend on a range of factors. These include the size and complexity of hazard-prone areas, availability of secondary information, statistical data and access to data sets. It will also depend on the systems that are required to manage the information on a long-term basis for both fisheries and aquaculture management and disaster preparedness.

5.2.5 Information requirements of a fisheries and aquaculture baseline

Table 4 provides a summary of the structure and key information requirements of a fisheries and aquaculture baseline. Technical guidance for undertaking the assessment is included in the Annexes.

5.3 INITIAL IMPACT APPRAISAL

5.3.1 What does it aim to achieve?

An initial impact appraisal gathers basic information on the damage, needs and existing capacities of the affected population, possible areas of intervention and resource requirements.

The initial impact appraisal aims to provide the initial flash appeal with a set of figures that define the overall requirements of the fisheries and aquaculture sector for rehabilitation and reconstruction so that the process of mobilizing funding can begin. In the context of the immediate aftermath of a serious disaster, with limited information available and limited possibilities of direct visits, and where it may be difficult (and not even desirable) to carry out field investigations with traumatized disaster victims, it may be a considerable challenge to make a reasonable assessment of the eventual losses and costs involved in rehabilitation. However, the important thing at this stage is to generate figures that will allow the mobilization of funds so that rehabilitation and reconstruction work can begin as soon as conditions allow.

The objectives of the initial impact appraisal are:

- to build up a first layer of data analysis to allow the authorities to take informed decisions and to also allow the formulation of the first immediate projects to be presented in the flash appeal;
- to set the basis for the further analysis and the elaboration of a more detailed fully fledged fisheries and aquaculture recovery response plan and proposal;
- to identify areas and issues for more detailed follow-up in a subsequent detailed fisheries and aquaculture sector assessment.

5.3.2 When is it done?

The initial impact appraisal is undertaken as soon as possible after an emergency has been declared. An initial impact appraisal should take one week or less so that the findings can be fed into the initial flash appeal mechanism

TABLE 4

Information for the fisheries and aquaculture baseline

	Key considerations	Potential sources of information
Disaster preparedness work	<p>Other baseline work</p> <ul style="list-style-type: none"> • Disaster preparedness work • Other cluster studies • Livelihoods information • Institutions roles and responsibilities 	<ul style="list-style-type: none"> • Government departments responsible for disaster prevention, preparedness, response and recovery • Cluster leaders
Contextual information	<p>Population of the area:</p> <ul style="list-style-type: none"> • Fisheries and aquaculture village/settlement details • Fisheries and aquaculture stakeholders <p>Past disasters and response work</p> <ul style="list-style-type: none"> • Lessons learned and guidance 	<ul style="list-style-type: none"> • Government fisheries departments • Fisheries development projects • Government departments responsible for disaster prevention, preparedness, response and recovery • Cluster leaders
Institutions	<p>Government departments and mandates</p> <ul style="list-style-type: none"> • Fisheries and aquaculture • Disaster response <p>Service providers</p> <ul style="list-style-type: none"> • Private sector • NGOs • CBOs 	<ul style="list-style-type: none"> • Government departments responsible for disaster prevention, preparedness, response and recovery • UN Agencies • INGOs and NGOs
Fisheries and aquaculture policy and management	<p>Existing policies and practices</p> <ul style="list-style-type: none"> • Existing fisheries and aquaculture policies in respect on national development objectives • Existing subsector policies relating to fisheries operations, post-harvest fisheries and aquaculture • The current and future role of fish in food and nutrition security <p>Existing policy implementation instruments</p> <ul style="list-style-type: none"> • Existing management strategies and priorities • Policy instruments 	<ul style="list-style-type: none"> • National development plans • Sector development policies and plans • Sector legislation • Annual sector reports • Extension, enforcement and research infrastructure and activity reports • Staffing and reporting databases

TABLE 4 (cont.)

	Key considerations	Potential sources of information
<p>Fisheries and aquaculture livelihoods</p>	<p>Human capital</p> <ul style="list-style-type: none"> • Fishing skills • Fishing knowledge • Education • Health and welfare <p>Social capital</p> <ul style="list-style-type: none"> • Organization in the community • Relationships between groups • Fishers organizations <p>Financial</p> <ul style="list-style-type: none"> • Systems and access to credit and savings • Credit relationships (financial capital) <p>Natural</p> <ul style="list-style-type: none"> • Access to the resources 	<ul style="list-style-type: none"> • Past development projects • Participatory appraisal • Census data • Representatives of government institutions, especially at local level (e.g. local fisheries officers if any), fisheries administrations, coastguards, marine department • FAO Representative, other UN Agencies involved in fisheries (such as UNDP, UNICEF) and International Federation of Red Cross and Crescent Societies (IFRC) • Fish farmers, fisherfolk, representatives of fishery communities, fisherfolk associations and other local and international NGOs • Academics, researchers, universities • FAO Fishery and Aquaculture Department - www.fao.org/fishery/en • FAO Fishery Country Profiles: www.fao.org/fi/fc/fcp.asp
<p>Fisheries baseline</p>	<p>Types of fisheries</p> <ul style="list-style-type: none"> • Numbers of fishers (licenses and unlicensed) • Landings statistics • Types of fishing vessels (including specifications for typical vessels) • Fishing engines (including specifications of typical engines) • Fishing seasons • Types and numbers of fishing gear (including specifications of typical gear type) <p>National and local policies and management strategies</p> <ul style="list-style-type: none"> • Fishing zones • Input regulations • Conservation commitments • Departmental mandates • Licensing rules • Research capacity 	<p>Fisheries Global Information System (FIGIS) provides information on fishing technologies: www.fao.org/figis/</p> <ul style="list-style-type: none"> • National disaster coordination structures (local and national levels). • The FAO Fisheries and Aquaculture Department's library (FI-library@fao.org)

TABLE 4 (cont.)

	Key considerations	Potential sources of information
<p>Post-harvest fisheries & markets baseline</p>	<p>Fish supply chains</p> <ul style="list-style-type: none"> • Relationships between fishers/fish farmers and input/output merchants • Types of equipment and infrastructure used for trade • Guide of seasonal prices <p>Role of women in processing and trade</p> <p>Post-harvest processing methods</p> <ul style="list-style-type: none"> • Methods used (e.g. ice facilities, smoking, drying, fermentation) • Equipment used • Infrastructure • Employment 	
<p>Landing sites baseline</p>	<p>Shore-based structures</p> <ul style="list-style-type: none"> • Location of structures • Materials, size and construction type of structures <p>Social and management factors:</p> <ul style="list-style-type: none"> • Number and type of vessels using the facilities (seasonality of catches) • Management arrangements, ownership and jurisdiction • Community groups and cooperatives their roles and functions (including non-fishers) • Fishers credit and finance arrangements (where linked to landing facilities) 	
<p>Aquaculture</p>	<p>Sector details:</p> <ul style="list-style-type: none"> • Geographic location of aquaculture establishments by type • Area under aquaculture by type • Species under culture by type of aquaculture • Production trends by type of aquaculture and species • Abandoned and non-operational aquaculture establishments • Processing plants <p>Aquaculture community and dependence:</p> <ul style="list-style-type: none"> • Typical wages • Livelihood diversity 	

TABLE 4 (cont.)

	Key considerations	Potential sources of information
Aquaculture	<p>Equipment:</p> <ul style="list-style-type: none"> • Types of equipment used and cost <p>Critical inputs:</p> <ul style="list-style-type: none"> • Water sources by type of aquaculture • Seed supply sources • Feed supply sources • Fertilizer supply sources <p>Infrastructure:</p> <ul style="list-style-type: none"> • Power supply • Transportation • Communication 	
Environment	<p>Environment status:</p> <ul style="list-style-type: none"> • Marine environment • Freshwater environment • Biomass of key species • Biodiversity • Ecosystem integrity 	<ul style="list-style-type: none"> • Pre-disaster status reports on the environment, e.g. GEF reports, reports and databases on aquatic biodiversity, fisheries and aquaculture • Environmental impact assessments • Information regarding risk mapping and analysis • Land and water maps related to fisheries and aquaculture

as quickly as possible. The time involved will depend considerably on the baseline information available and, if a visit to location is carried out, the accessibility of affected areas.

Where possible, the initial impact assessment should be based on first-hand contact with the affected area and populations. However, this is often not possible, in which case baseline information may constitute the main source for the assessment.

5.3.3 What information should the initial impact appraisal contain?

Table 5 reviews some of the key areas of information that should be covered by the initial impact appraisal.

TABLE 5

Information to be covered by an initial impact appraisal

1. What was the pre-disaster baseline?
<p>The fisheries and aquaculture baseline information should provide the basis for the assessment of damage and needs.</p> <p>For guidance, see:</p> <ul style="list-style-type: none"> • Section 4.1 and Annexes 1–6
2. What is the current status?
<p>This information clarifies the magnitude and location of the event and the populations that have been exposed to it.</p> <p>2.1 The type and magnitude of the disaster (earthquake, tsunami, cyclone, etc.)</p> <p>2.2 The area affected by the disaster</p> <p>2.3 The human toll</p> <ul style="list-style-type: none"> • Injuries and deaths • Prevalence of disease • Any significant movements of people as a result • Status of food and nutrition security <p>2.4 The local, national and international response</p> <ul style="list-style-type: none"> • Who is coordinating the response? • What services and facilities are available – for victims and the response teams? • What other emergency response teams are likely to deliver? • Systems for coordination of assessment and aid delivery? • What role can fish supplies play in the immediate post-disaster situation to support food and nutrition security? <p>2.5 What steps need to be taken to ensure the safety of the assessment team?</p> <p>2.6 What steps need to be taken to ensure the safety of respondents to the assessment?</p> <p>For guidance, see:</p> <ul style="list-style-type: none"> • Livelihoods Assessment Toolkit (Volume 3 – Initial Impact Appraisal)

(cont.)

3. What are the impacts of the disaster on fisheries and aquaculture?

A key question at this stage will be to what extent have fisheries and aquaculture been affected. To determine a clear basis for fisheries or aquaculture interventions teams should report on the impacts according to the following areas:

- 3.1 Fisheries livelihoods
- 3.2 Fisheries and aquaculture policy and management (see Annex 1)
- 3.3 Capture fisheries (see Annex 2)
- 3.4 Fisheries infrastructure (see Annex 3)
- 3.5 Aquaculture (see Annex 4)
- 3.6 Post-harvest fisheries (see Annex 5)
- 3.7 The environment (see Annex 6)

For guidance, see:

- For summary tables and reporting structures, see Annexes 1–6

4. What is required to help people to recover to a “pre-disaster state”?

- 4.1 How can the fishing sector contribute to the immediate relief operation?
 - What is the availability of fish and fisheries products as key protein sources?
 - What is the availability of equipment and/or fishing boats for search and rescue?
 - What is needed to facilitate this support?
- 4.2 What are the rehabilitation requirements?*

 - In terms of fisheries livelihoods needs?
 - In terms of direct inputs for fisheries and aquaculture?
 - In terms of supporting services?
 - For further planning needs?
 - What are the time frames?

What are the linkages with wider recovery and development programmes?

For guidance, see:

- Annexes 1–6 – for details of summary tables

* At this stage, it will only be possible to give rough estimates of costs to rehabilitate the fisheries and aquaculture sector. In the detailed assessment, these costs will need to be considered in the context of longer-term development aspirations and other disaster response initiatives, before the proposals for support can be refined.

Further considerations for the initial impact appraisal

It will not be possible to address fully all of the areas in the framework above, and much of the initial impact appraisal may need to be based on secondary information and extrapolation from the baseline. However:

- It is essential that the team is clear about where and how assumptions have been made.
- Where it is not possible to make informed estimates, the team should ensure that the information requirements are highlighted so that they may be addressed in the detailed assessment.

5.4 DETAILED SECTOR ASSESSMENT

5.4.1 *What does it aim to achieve?*

The main objective of the detailed sector assessment is to provide a thorough assessment of the impact of disaster on livelihoods and identify opportunities and capacities for recovery at household, community, and local economy levels. In this way, it is intended to serve as a platform for local and central government authorities, in partnership with the international community to take informed decisions and focus assistance by providing a sound basis on which fisheries and aquaculture response plans and projects can be elaborated. The demands for information from the detailed sector assessment call for results to be ready within three months after the onset of a disaster.

One of the most important aims of the detailed sector assessment is that it provides information of sufficient quantity and quality to allow credible fisheries and aquaculture project proposals to be written. This is in recognition of the fact that, in a post-disaster context, revised flash appeals and early-recovery donor conferences may take place as soon as 6–8 weeks after a disaster. In such cases, there will not be sufficient time to conduct in-depth project planning.

Some of the key questions the detailed sector assessment will help to answer are:

- How were people (males and females) making a living before the disaster?
- What effect has the disaster had on their livelihoods?
- What effect has the disaster had on the supply of fish and income sources within fisheries and aquaculture communities?
- How can fish and fisheries products contribute to immediate food and nutrition security?
- How has the aquatic resource base been affected?
- What coping mechanisms and livelihood strategies have different people, households and businesses developed, and how effective and/or damaging are these?
- What are the opportunities and capacities for recovery of the environment and economy?
- How can disaster rehabilitation stream into long-term development strategies for the local communities and the nation as a whole?
- What types of activities are needed for livelihood recovery of the different people, households, businesses and communities?
- How can policies and management systems be reformulated to ensure that “build back better” is the reality?

Ideally, this detailed assessment should be used in conjunction with a pre-prepared fisheries and aquaculture baseline. This baseline should provide important contextualization and quantification of the pre-disaster situation and allow a better analysis of the changes caused the disaster.

In practice, baselines may not exist, or where they do, they may be fragmented and partial. In such cases, the fisheries and aquaculture detailed assessment itself should include the collection of appropriate and sufficient baseline information.

5.4.2 When is it done?

There will be time pressures when planning and implementing the fisheries and aquaculture detailed assessment, and certain compromises will have to be made. In particular, there will be trade-offs between the quality of the process and the need to communicate results quickly to meet deadlines imposed by the needs of the affected populations, governments and the international community.

Typically, a detailed sector assessment will take place within 90 days of the disaster and will take about five weeks from start to finish. The immediate output will be a report of about 30 pages directed at key decision-makers.

There are three phases in the process of undertaking a detailed sector assessment:

- **Phase 1 – Start up; initial information collection and detailed planning:** The first phase is characterized by an intensive period of information gathering using various formal and informal sources to gain an initial picture of the situation and context. This period will also involve a lot of meetings to sort out logistics and planning the fieldwork and training. This will involve selecting the sample area, assembling the team, deciding on the time frame, consolidating the budget and working out logistics such as transport, lodgings, etc.
- **Phase 2 – Fieldwork:** To be based around a process designed to validate information about impacts and elicit demands for assistance.
- **Phase 3 – Write up presentation and dissemination:** This final stage consists of the final analysis and write-up of the actual assessment, presentation to government, and dissemination. This may be followed by preparation of a “road map” for livelihood recovery (e.g. a draft logical framework) and related project proposals.

5.4.3 What information should the detailed assessment contain?

Table 6 outlines the key areas of information that should be covered by the detailed sector assessment.

TABLE 6

Information to be covered by the detailed sector assessment**1. What was the pre-disaster baseline?**

The fisheries and aquaculture baseline information provides the basis for the assessment of damage and needs.

For guidance, see:

- Section 5 and Annexes 1–6

2. What is the current status?

This information clarifies the magnitude and location of the event and the populations that have been exposed to it. In the detailed assessment, the team will have the opportunity to update and validate the report in the initial assessment. The information should include:

- 2.1 The type and magnitude of the disaster (earthquake, tsunami, cyclone, etc.)
- 2.2 The area affected by the disaster
- 2.3 The human toll
 - Injuries and deaths
 - Prevalence of disease
 - Any significant movements of people as a result
 - Availability of food and nutrition
- 2.4 The local, national and international response
 - Who is coordinating the response?
 - What services and facilities are available – for victims and the response teams?
 - What other emergency response teams are likely to deliver?
 - Systems for coordination of assessment and aid delivery?
- 2.5 What steps need to be taken to ensure the safety of the assessment team?
- 2.6 What steps need to be taken to ensure the safety of respondents to the assessment?

For guidance, see:

- Disaster section (checklist)
- Initial impact appraisal
- Livelihoods Assessment Toolkit (Volume 4 – Detailed Livelihood Assessment)

3. What are the impacts of the disaster on fisheries and aquaculture?

Information generated in the initial impact appraisal should be reviewed and validated at the local and national levels.

To set the basis for project proposals to support the rehabilitation and development of the fisheries sectors, the assessment teams should report on the impacts according to the following areas:

- 3.1 Fisheries livelihoods
- 3.2 Fisheries and aquaculture policy and management (see Annex 1)
- 3.3 Capture fisheries (see Annex 2)
- 3.4 Post-harvest fisheries (see Annex 3)
- 3.5 Fisheries infrastructure (see Annex 4)
- 3.6 Aquaculture (see Annex 6)
- 3.7 The environment (see Annex 6)

For guidance, see:

- For summary tables and reporting structures, see Annexes 1–6

(cont.)

4. What is required to help people to recover to a “pre-disaster state”?

- 4.1 Opportunities for assistance – based on an understanding of current response and capabilities of the affected populations –
 - Fisheries livelihoods needs
 - Support for fisheries policies, management and administrations
 - Direct inputs for fisheries and aquaculture
 - Post-harvest fisheries
 - Environmental measures
- 4.2 Quantities and costs
- 4.3 Channels for delivery
- 4.4 Linkages with wider recovery and development programmes

For guidance, see:

- Annexes 1–6

Annex 1

Fisheries and aquaculture policy and management

A1.1 INTRODUCTION

For the purposes of this document, policies can be thought of as the choices that governments and other bodies make in terms of their aims and how those aims will be achieved. Management can be seen as the means and actions needed to implement policy.

Disasters can have a profound effect on fisheries and aquaculture policies and management. In some situations, disasters make existing policies for development temporarily redundant. In other cases, they can shift the whole focus of policies or threaten to undermine those policies. However, they also offer the opportunity to build back better by reshaping policies and policy implementation in ways that are fairer, more resilient and more sustainable.

A1.2 EFFECTS OF DISASTERS ON POLICIES AND MANAGEMENT

Disasters can have a significant effect on many aspects of policies and the way policy implementation is managed. Key changes that are likely to affect policies include:

- The loss of life of fishers, fish farmers, their families, ancillary workers, government officials, and other members of the local society that generate the local economy and play key roles in the leadership, governance and support for the sector.
- Damage to government infrastructure in the sector.
- Loss of assets for the fisheries and fish farmers – not just those relating to fishing and fish farming, but also wider assets such as houses, means of transport, schools, medical facilities and meeting rooms.
- Decreased food and nutrition security as a result of declining fish harvests affecting both the local supply of fish and the ability of fishers and fish farmers to buy food.
- Disruption of livelihood strategies of all affected groups.
- Environmental impacts such as damage to habitats, changes in water quality, release of farmed fish into the wild, and pollution from toxic materials that can kill fish or affect their flavour.
- Loss of market confidence in the quality of fish and, thus, a reduced selling price.
- Increased conflicts leading to a difficult operating environment for local people and government staff.
- Increased corruption as a result of the disruption caused by disasters.

These changes are likely to change the immediate emphasis of policy and policy implementation, and some examples of how that might occur are given below.

The loss of life is likely to affect the dynamics of the fisheries sector and to affect household livelihood strategies significantly. A change in gender balance in communities as a result of a disaster will require changes in the way development policy is to be implemented. The loss of life may also change the leadership structure in communities – reducing the voice of poorer groups. This may require a shift in the way policy is implemented such that a greater focus is placed on group formation and rebuilding of community structures and processes.

The loss of private assets will be particularly significant for the poor even though their losses may be less in monetary terms than those of richer people. This may require the careful use of subsidies to re-establish productive capacity. The loss of houses of poorer people who have limited tenure over coastal land may mean that those people are subjected to pressures to leave the location so that others can move into the area. Conflicts between fishing communities and the tourism sector may, for example, require cross-sectoral policy coordination.

The loss of government staff may also affect the efficiency and effectiveness of ongoing development activities and disaster response mechanisms. This will be further challenged by the damage and loss of government infrastructure, which may limit immediate recovery and rehabilitation efforts and influence build-back approaches.

A key change is likely to be a shift in funds from development budgets to recovery budgets and, thus, for policy implementation in other areas to slip. In situations where good baselines of gear, boats and infrastructure have not been established, there will be the potential for changes in the lost fishing capacity to be over overstated and for less sustainable fisheries to be built back.

The role of the fisheries and aquaculture sector is also likely to be significant in terms of input to food and nutrition security, and the effects of a disaster are likely to affect this input. This may be further affected through the damage or loss of post-harvest equipment such as drying racks, freezers and ice plants. This may require a short- to medium-term shift in of policy focus in the sector to rebalance domestic consumption and exports.

Environmental changes as a result of the disaster might also stimulate the need for policy changes to protect damaged ecosystems or species. In some cases, contaminated fish may have to be removed from sale in order to protect consumers. This may need to be followed by support to market and consumer groups to rebuild confidence in the products.

Any form of disruption on the scale that a disaster can create can stimulate some people to see this as an opportunity to engage in corrupt practices. Particular efforts by policy-makers will be needed to ensure that this is minimized.

A1.3 THREATS TO GOOD POLICY AND MANAGEMENT PROCESSES IN POST-DISASTER SITUATIONS

While the response to a disaster may be well intentioned, there are circumstances where threats to good policy can arise. These need to be borne in mind and addressed where necessary:

- **Short-term pressures:** The understandable emphasis immediately after a disaster on the short-term needs of the affected populations may undermine or conflict with longer-term policy goals. Subsidies, put in place to help rehabilitation, are easier to put in place than to remove after the disaster has passed. Similarly, the premature reintroduction of fish to the market after a pollution event and before consumer confidence has been fully restored may have long-term effects on markets.
- **Weak coordination:** A lack of coordination between different agencies during an emergency or in a post-disaster situation may also result in policy conflicts that can have significant adverse effects. Environmental policy may conflict with the needs of the poor, a focus on agriculture may disadvantage fish farmers, and assistance in the form of food aid may disrupt fragile markets for fish.
- **Loss of local leadership:** The loss of key government staff or community leaders can lead to local communities losing their representatives and a reduction in their capacity to influence decision-making. This in turn can lead to the introduction of inappropriate policies that do not reflect local needs and aspirations or that favour some groups over others.
- **Poorly planned asset replacement:** In the rush to restore normality, the restoration of fisheries and aquaculture infrastructure and assets can lead to adverse environmental effects. This is particularly so where fishing gear is inappropriately selected, boats are either poorly constructed or made to inappropriate designs, or fish farms are poorly sited.
- **Environmental expediency:** The urgent need to restore order to damaged environments can lead to decisions being made that bypass established governance systems and undermine trust that could adversely influence future management measures.
- **Long-term aid dependence:** Recovery and rehabilitation support can stimulate long-term dependence, which reduces the resilience and adaptive capacity of communities.
- **Cost savings:** The need to save costs or generate value for money in the short term may lead to technologies and processes that are suboptimal in the long term. Poorly built boats, for example, may lead to high maintenance or loss of life. Cheaper engines may lead to increased fuel consumption and more expensive repairs.

It is important to consider these threats to good policy when planning and implementing needs assessments.

A1.4 OPPORTUNITIES TO IMPROVE FISHERIES AND AQUACULTURE POLICIES

While there are a number of threats to the policy environment, disasters also provide an opportunity to refine policies and management to ensure that the sector builds back better. There is an increasing need to build disaster risk management into fisheries and aquaculture policies and management systems. The post-disaster situation creates an opportunity to reflect on the Hyogo Framework for Action (HFA) and its application to the fisheries and aquaculture sector. The HFA is a plan to explain, describe and detail the work that is required to reduce disaster losses. The HFA outlines five priorities for action, and offers guiding principles and practical means for achieving disaster resilience:

- Ensure that disaster risk reduction is a national and a local priority with a strong institutional basis for implementation.
- Identify, assess and monitor disaster risks and enhance early warning.
- Use knowledge, innovation and education to build a culture of safety and resilience at all levels.
- Reduce the underlying risk factors.
- Strengthen disaster preparedness for effective response at all levels.

FAO has developed a Disaster Risk Reduction Framework that reflects the HFA and strives to assist Members implement its five priorities for action for the agriculture sector. It covers four broad areas for achieving this. These are summarized below.

Enable the environment: This seeks to support the enabling environment of Members, with appropriate legislation, policies and institutional frameworks for disaster risk reduction for food and nutrition security in agriculture, livestock, fisheries/aquaculture, forestry and natural resource management, and to strengthen the institutional capacities to implement these. Examples within the fisheries and aquaculture sector are:

- placing a greater emphasis on disaster risk reduction in the sector;
- building comprehensive baselines and other management information systems;
- linking fisheries and aquaculture policy more closely to wider development policies and those for local economic growth;
- developing improved contingency plans and risk assessment methods.

Watch to safeguard: This seeks to strengthen and harmonize food and nutrition security information and early warning systems to better monitor the multiple threats and inform decision-making in preparedness, response, policy, advocacy and programming. Examples within the fisheries and aquaculture sector are:

- building improved early warning systems within the sector and linking these to those of other sectors;
- developing policies and institutions for better responses to disasters;
- improving the role of fish and fisheries products in food and nutrition security in the event of disasters.

Prepare to respond: This seeks to strengthen capacities at all levels in preparedness to improve response to, and recovery from, future threats to food and nutrition security, and to reduce their potential negative impact on livelihoods. Examples within the fisheries and aquaculture sector are:

- understanding the effects of the disaster on different groups of people, and building this knowledge into future planning;
- supporting measures to provide protection to communities from disasters in the future;
- building capacity within government, civil society and communities to respond better to future disasters;
- building measures to allow a greater involvement of fish and fisheries products in ensuring food and nutrition security in post-disaster situations;
- using subsidies and other support measure in ways that do not generate long-term dependence.

Build resilience: This seeks to address the underlying risks to food and nutrition security and to build the resilience of livelihoods through the application of technologies, practices and approaches in farming, fisheries/aquaculture, forestry and natural resource management. Examples within the fisheries and aquaculture sector are:

- working with fishers, fish farmers and their communities to build their resilience to all kinds of future disasters, especially through reduced dependence on fisheries and through the development of diversified and alternative livelihoods linked to local and national economies;
- building resilience in fish post-harvest and marketing systems to avoid losses and to assist their continued functioning in the face of future disasters;
- building the resilience of wider society to changes in the fisheries sector as a result of disasters;
- building improved fisheries management systems to ensure that fisheries resources and ecosystems have the capacity to recover quickly from disasters (in particular, ensuring that catching capacity is in balance with available resources);
- combining ecosystem approaches to management with those that support community-based adaptation, especially with increased emphasis on participation in governance systems;
- building improved policies for aquaculture planning and management to ensure both reduced exposure to risk and reduced environmental effects.

In the post-disaster situation, it is important to review the sector and its performance, and the benefits it generates, and restructure it in a way that is more sustainable, efficient and will ensure a more equitable distribution of benefits.

A1.5 KEY INFORMATION NEEDS FOR DAMAGE NEEDS ASSESSMENT: POLICY AND MANAGEMENT

The sorts of information that are needed in an assessment in a disaster situation, to address policy and management issues, include baseline information and information about changes that have occurred. Some key questions that will assist in implementing an assessment of the policy and management situation are outlined below.

A1.5.1 Contribution to national development objectives

A1.5.1.1 Baseline

- What contribution does the fisheries and aquaculture sector make to the national economy in terms of employment, poverty reduction, food and nutrition security, export earnings and economic growth?
- What aims and objectives have been established for the development of the sector?
- What aims and objectives have been established for the development of different subsectors?
- What strategies have been put in place to achieve these aims?
- What policy instruments are in place to delivery these aims (e.g. legislation, funding, loans, enforcement services, extension services, research services, information provision, training, equipment)?
- What fish stock management measures have been put in place?
- What are the governance systems for managing the fisheries and aquaculture sector?

A1.5.1.2 Impact appraisal

- How has the contribution of the sector to national development objectives been affected by the disaster?
- How has government infrastructure and equipment been affected by the disaster?
- How have enforcement, extension and research services been affected by the disaster?
- How has the government's ability to deal with the disaster been affected?
- How will fisheries policies and management measures need to change to respond to the disaster and in the post-disaster phase?
- What threats to policy and management exist and how will they be dealt with?

A1.5.2 People in the sector

A1.5.2.1 Baseline

- How many people are employed in the different subsectors of the fisheries and aquaculture sector (e.g. fishers [men and women], fish farmers, processors, traders, transporters, net makers, boat builders, moneylenders, and engine repairers)?
- To what extent are their livelihoods dependent on the sector?

A1.5.2.2 Impact appraisal

- How many, which groups and by how much have they been affected by the disaster?
- Where are these affected people concentrated?

A1.5.3 Asset ownership

A1.5.3.1 Baseline

- What are the broad categories of asset types related to the operation of the sector held by the different groups (e.g. houses, boats, engines, nets, fish ponds, pumps, generators, tools, processing equipment, transport vehicles, markets)? Reference should be made to the assessments carried out in the other annexes.
- What assets are owned by the fisheries administration (including boats, offices, vehicles, laboratories)?
- Where are they distributed?

A1.5.3.2 Impact appraisal

- How have these public and private assets been affected by the disaster?
- How has this affected the contribution of the sector to national development objectives?
- How has this affected government's ability to reform?

A1.5.4 Food and nutrition security

A1.5.4.1 Baseline

- What is the contribution of the sector to food and nutrition security locally and nationally?
- How many people depend upon the sector for food and nutrition security?
- To what extent do they depend upon the sector?
- What are broad consumer attitudes to fish?

A1.5.4.2 Impact appraisal

- How has food and nutrition security been affected by the disaster?
- What contribution can fish play in the recovery and rehabilitation process?
- How have consumer attitudes changed?

A1.5.5 Conflict in the sector

A1.5.5.1 Baseline

- To what extent did conflict exist in the sector before the disaster?
- Which groups were involved and why?
- What measures were being adopted to address the conflict?

A1.5.5.2 Impact appraisal

- How has the conflict changed since the disaster?
- Who is affected most and in what way?

A1.5.6 Corruption and illegal activity

A1.5.6.1 Baseline

- To what extent does corruption and illegal behaviour occur in the sector?
- Where and in what form does it appear?
- What efforts are being made to address it?

A1.5.5.2 Impact appraisal

- How has it changed since the disaster?

A1.6 KEY RESOURCES

A1.6.1 Web references

- FAO. 2001. *International Plan of Action to Prevent, Deter and Eliminate Illegal, Unreported and Unregulated Fishing* [online]. Rome. [Cited 20 May 2013]. www.fao.org/docrep/003/y1224e/y1224e00.HTM
- FAO. 2010–2013. International Plan of Action for Conservation and Management of Sharks. In: *FAO Fisheries and Aquaculture Department* [online]. Rome. [Cited 20 May 2013]. www.fao.org/fishery/ipoa-sharks/en
- FAO. 2010–2013. International Plan of Action for the Management of Fishing Capacity. In: *FAO Fisheries and Aquaculture Department* [online]. Rome. [Cited 20 May 2013]. www.fao.org/fishery/ipoa-capacity/en
- FAO. 2010–2013. International Plans of Action for Reducing Incidental Catch of Seabirds in Longline Fisheries. In: *FAO Fisheries and Aquaculture Department* [online]. Rome. [Cited 20 May 2013]. www.fao.org/fishery/ipoa-seabirds/en
- FAO. 2011–2013. EAFnet. In: *FAO Fisheries and Aquaculture Department* [online]. Rome. [Cited 20 May 2013]. www.fao.org/fishery/eaf-net/en
- FAO. (various years). Code of Conduct for Responsible Fisheries: Technical Guidelines. In: *FAO Fisheries and Aquaculture Department* [online]. Rome. [Cited 20 May 2013]. www.fao.org/fishery/code/publications/guidelines/en
- FAO Strengthening Decision Making in Relief and Recovery Improved Response Analysis Capacity Project <http://home.wfp.org/stellent/groups/public/documents/ena/wfp194140.pdf>

- FAO, NACA, UNEP, WB & WWF. 2006. *International Principles for Responsible Shrimp Farming* [online]. [Cited 20 May 2013]. www.enaca.org/uploads/international-shrimp-principles-06.pdf
- Global Aquaculture Alliance.** 2011. BAP Standards. In: *Global Aquaculture Alliance* [online]. [Cited 20 May 2013]. www.gaalliance.org/bap/standards.php
- ICES Code of Practice on the on the Introductions and Transfers of Marine Organisms** <http://www.ices.dk/reports/general/2003/Codemarineintroductions2003.pdf>
- International Maritime Organization (IMO).** 2013. *International Maritime Organization* [online]. Various guides and manuals on oil pollution, chemical pollution, oil spill responses, clean up operations. [Cited 20 May 2013]. www.imo.org/Pages/home.aspx
- International Oil Pollution Compensation Fund 1992.** 2008. *Guidelines for presenting claims in the fisheries, mariculture and fish processing sector* [online]. [Cited 20 May 2013]. www.iopcfunds.org/uploads/tx_iopcpublishations/Fisheries_Guidelines_-_Claimants_e.pdf
- International Oil Pollution Compensation Funds.** 2008. *Technical guidelines for assessing fisheries sector claims, with special reference to small-scale operations lacking evidence of earnings fisheries where data may be lacking* [online]. [Cited 20 May 2013]. http://www.iopcfunds.org/uploads/tx_iopcpublishations/Fisheries_Expert_Guidelines_e.pdf
- IOE.** 2011. *Aquatic Animal Health Code* [online]. Paris. [Cited 20 May 2013]. www.oie.int/doc/ged/D10907.PDF
- Marine Stewardship Council.** 2013. *Marine Stewardship Council* [online]. [Cited 20 May 2013]. www.msc.org
- Oxfam.** 2012. Emergency Food Security and Livelihoods Programme. In: *Oxfam* [online]. [Cited 20 May 2013]. <http://policy-practice.oxfam.org.uk/our-work/conflict-disasters/food-security>
- WWF.** 2013. Aquaculture Dialogue standards. In: *WWF* [online]. [Cited 20 May 2013]. <http://worldwildlife.org/industries/farmed-seafood>

A1.6.2 Literature references

- American Red Cross & FAO.** 2005. *Rehabilitation and development of sustainable livelihoods of tsunami affected coastal communities in Indonesia and Sri Lanka.*
- Arthur, J.R., Bondad-Reantaso, M.G., Campbell, M.L., Hewitt, C.L., Phillips, M.J. & Subasinghe, R.P.** 2009. *Understanding and applying risk analysis in aquaculture: a manual for decision-makers* FAO Fisheries and Aquaculture Technical Paper No. 519/1. Rome, FAO. 113 pp. (also available at www.fao.org/docrep/012/i1136e/i1136e.pdf).
- Asian Development Bank.** 2009. *Earthquake and tsunami emergency support project (fisheries component), Indonesia.* Sep 06 – Dec 08.
- Bailey, C.** 2008. Human dimensions of an ecosystem approach to aquaculture. In D. Soto, J. Aguilar-Manjarrez & N. Hishamunda, eds. *Building an ecosystem approach to aquaculture, FAO/Universitat de les Illes Balears Expert Workshop, 7–11 May*

- 2007, *Palma de Mallorca, Spain*, pp. 37–46. FAO Fisheries and Aquaculture Proceedings No. 14. Rome, FAO. 221 pp. (also available at <ftp://ftp.fao.org/docrep/fao/011/i03339e/i03339e.pdf>).
- Banks, R.** 2006. *Marine Fisheries Master Plan for Re-Development in Aceh, Indonesia: Phase 1: Initial Fact-Finding and Data Collection on Current State of the Marine Fisheries Sector*. Prepared for International Finance Corporation Private Enterprise Partnership for Aceh and Nias and Rehabilitation and Reconstruction Agency Aceh-Nias by Poseidon Aquatic Resource Management Ltd, UK.
- Barrett, C.B., Bell, R., Lentz, E.C. & Maxwell, D.G.** 2009. Market information and food insecurity response analysis. *Food Security*, (2009) 1: 151–168. www.cashlearning.org/downloads/resources/documents/barrett-et-al-mifira-food-security-june-2009.pdf
- Bennett, J., Bertrand, W., Harkin, C., Samarasinghe, S. & Wickramatillake, H.** 2006. *Coordination of international humanitarian assistance in tsunami-affected countries*. London, Tsunami Evaluation Coalition.
- Beqiri, M.** 2006. *Inception / Progress Report: Regional information management and co-ordination on strategies for early recovery of agriculture in coastal regions in Indonesia, Maldives, Sri Lanka and Thailand affected by tsunami*. OSRO/RAS/503/CHA.
- Brugère, C., Ridler, N., Haylor, G., Macfadyen, G. & Hishamunda, N.** 2010. *Aquaculture planning: policy formulation and implementation for sustainable development*. FAO Fisheries and Aquaculture Technical Paper No. 542. Rome, FAO. 70 pp. (also available at www.fao.org/docrep/012/i1601e/i1601e00.pdf).
- Clinton, W.** 2006. *Lessons learned from tsunami recovery. Key Propositions for Building Back Better*. A Report by the United Nations Secretary-General's Special Envoy for Tsunami Recovery, William J. Clinton.
- Cochrane, K.L., ed.** 2002. *A fishery manager's guidebook – management measures and their application*. FAO Fisheries Technical Paper No. 424. Rome, FAO. 231 pp. (also available at <ftp://ftp.fao.org/docrep/fao/004/y3427e/y3427e00.pdf>).
- FAO.** 1995. *Code of Conduct for Responsible Fisheries*. Rome. 41 pp. (also available at www.fao.org/docrep/005/v9878e/v9878e00.HTM).
- FAO.** 1997. *Aquaculture development*. FAO Technical Guidelines for Responsible Fisheries No. 5. Rome. 40 pp. (also available at <ftp://ftp.fao.org/docrep/fao/003/W4493e/W4493e00.pdf>).
- FAO.** 2003. *Fisheries Management – 2. The Ecosystem Approach to Fisheries*. FAO Technical Guidelines for Responsible Fisheries No. 4, Suppl. 2. Rome. (also available at www.fao.org/DOCREP/005/Y4470E/Y4470E00.HTM).
- FAO.** 2004. *Sri Lanka: emergency rehabilitation of the fishing sector in conflict-affected areas of Sri Lanka*. Project number: OSRO/SRL/302/GER.
- FAO.** 2006a. *Thailand: emergency assistance to the tsunami-affected fishing communities in southern Thailand*. THA/05/002.
- FAO.** 2006b. *Thailand: Strengthening the coordination and assessment of fishing resources and inputs provided by tsunami emergency relief* OSRO/THA/505/CHA.

- FAO. 2007. *Emergency assistance to tsunami-affected coastal communities in Aceh and North Sumatra*. (OSRO/INS/512/SPA) June 05 – May 06.
- FAO. 2008a. *Fisheries management. 3. Managing fishing capacity*. FAO Technical Guidelines for Responsible Fisheries No. 4, Suppl. 3. Rome. 104 pp. (also available at <ftp://ftp.fao.org/docrep/fao/011/i0318e/i0318e.pdf>).
- FAO. 2008b. *Myanmar emergency & rehabilitation programme needs assessment for the Cyclone Nargis affected areas agriculture (crops, livestock, fisheries, forestry)*.
- FAO. 2008c. *Report of the Expert Consultation on Improving Planning and Policy Development in Aquaculture, Rome, 26–29 February 2008*. FAO Fisheries Report No. 858. Rome. 18 pp. (also available at <ftp://ftp.fao.org/docrep/fao/011/i0205e/i0205e00.pdf>).
- FAO. 2009a. *Myanmar: immediate rehabilitation of subsistence fisheries livelihoods in areas affected by Cyclone Nargis*. OSRO/MYA/805/SWE.
- FAO. 2009b. *Environmental impact assessment and monitoring in aquaculture*. FAO Fisheries and Aquaculture Technical Paper No. 527. Rome. 57 pp. (also available at <ftp://ftp.fao.org/docrep/fao/012/i0970e/i0970e.pdf>).
- FAO. 2009c. *Fisheries management. 2. The ecosystem approach to fisheries. 2.2 The human dimensions of the ecosystem approach to fisheries*. FAO Technical Guidelines for Responsible Fisheries No. 4, Suppl. 2, Add. 2. Rome. 88 pp. (also available at <http://www.fao.org/docrep/012/i1146e/i1146e00.pdf>).
- FAO. 2010a. *Myanmar: Integrated shelter and livelihoods asset replacement for under-assisted coastal communities in seven village tracts of Labutta*. OSRO/MYA/905/UK.
- FAO. 2010b. *Rehabilitation and sustainable development of fisheries and aquaculture affected by the tsunami in Aceh Province, Indonesia*. Project OSRO/INS/601/ARC) end-of-project evaluation.
- FAO. 2010c. *Rehabilitation of livelihoods in the fisheries sector affected by the tsunami and earthquake in Indonesia*. (GCP/INS/076/GER) Dec 05 – Oct 08.
- FAO. 2011. *Developing a response analysis framework for food security: emergencies mapping of on-going response analysis processes*.
- FAO. (unpublished). Technical meeting on preparedness and response to nuclear and radiological emergencies affecting food and agriculture, including the application of agricultural countermeasures and remediation strategies. Concept note.
- FAO/NACA. 2000. *Asia Regional Technical Guidelines on Health Management for the Responsible Movement of Live Aquatic Animals and the Beijing Consensus and Implementation Strategy*. FAO Fisheries Technical Paper No. 402. Rome, FAO. 53 pp. (also available at www.fao.org/docrep/005/X8485E/X8485E00.HTM).
- FAO & ARC. 2005. *Joint ARC-FAO inception mission for the sustainable rehabilitation and development of livelihoods of coastal communities affected by the earthquakes and tsunami in Aceh Province and Nias Island, North Sumatra Province, Indonesia, and in Sri Lanka*. (OSRO/RAS/506/ARC) Sep 05 – 2009.
- Hartmann, W., Hamid, A.H., Sukadi, F., Koeshendrajana, S. & Ondrusek, R. 2010. *Rehabilitation and sustainable development of fisheries and aquaculture affected by*

- the tsunami in Aceh Province, Indonesia*. Project OSRO/INS/601/ARC. End of project evaluation report.
- IMM Ltd.** 2001. *Learning lessons from the cyclone; a study of DFID's support for post-cyclone livelihoods rehabilitation in Orissa, India*.
- IТОPF.** 2004. *Technical information paper: oil spill effects on fisheries*.
- Law, R.J. & Kelly, C.** 2004. The impact of the "Sea Empress" oil spill. *Aquatic Living Resources*, 17: 389–394.
- Livestock Emergency Guidelines and Standards.** 2009. *Livestock Emergency Guidelines and Standards* Practical Action Publishing. (also available at www.livestock-emergency.net/).
- Macfadyen, G., Huntington, T. & Cappell, R.** 2009. *Abandoned, lost or otherwise discarded fishing gear*. UNEP Regional Seas Reports and Studies No. 185; FAO Fisheries and Aquaculture Technical Paper No. 523. Rome, UNEP/FAO. 115 pp. (also available at [ftp://ftp.fao.org/docrep/fao/011/i0620e/i0620e.pdf](http://ftp.fao.org/docrep/fao/011/i0620e/i0620e.pdf)).
- NACA, Sloane Cook & King Pty Ltd & PT Trans Intra Asia.** 2007. *Earthquake and Tsunami Emergency Support Project (Fisheries Component), Indonesia*. Interim Report. Asian Development Bank Grant 0002-INO. 86 pp.
- Phillips, M.J., Enyuan, F., Gavine, F., Hooi, T.K., Kutty, M.N., Lopez, N.A., Mungkung, R., Ngan, T.T., White, P.G., Yamamoto, K. & Yokoyama, H.** 2009. Review of environmental impact assessment and monitoring in aquaculture in Asia-Pacific. In FAO. *Environmental impact assessment and monitoring in aquaculture*, pp. 153–283. FAO Fisheries and Aquaculture Technical Paper No. 527. Rome, FAO. 648 pp. (also available at [ftp://ftp.fao.org/docrep/fao/012/i0970e/i0970e.pdf](http://ftp.fao.org/docrep/fao/012/i0970e/i0970e.pdf)).
- Scheper, B., Parakrama, A. & Patel, S.** 2006. *Impact of the tsunami response on local and national capacities*. London, Tsunami Evaluation Coalition.
- TVE.** 2010. *Fighters to fishers*. Proposal to FAO for a 25-minute documentary for international broadcast, online and non-broadcast educational distribution.
- Westlund, L., Poulain, F., Bage, H. & van Anrooy, R.** 2007. *Disaster response and risk management in the fisheries sector*. FAO Fisheries Technical Paper No. 479. Rome, FAO. 56 pp. (also available at www.fao.org/docrep/010/a1217e/a1217e00.htm).
- World Organisation for Animal Health.** 2011. *Aquatic Animal Health Code*. Fourteenth addition.

Annex 2

Capture fisheries gear, vessels and engines

A2.1 INTRODUCTION

Fish capture technology encompasses the process of catching any aquatic animal, using any kind of fishing method, often operating from a boat in either marine or freshwater environments. The fishing methods used vary from the simple (such as hooks and hand-operated nets and traps) to sophisticated (such as midwater trawls or purse seines operated by large fishing vessels). The large diversity of target species in capture fisheries and their wide distribution requires a variety of fishing gear and methods for efficient harvest. These technologies have developed around the world according to local traditions and technological advances. Many fishers (especially small-scale ones) change the type of gear and target species or use multiple different gear according to season or market demand.

The major impact of a disaster affecting capture fisheries is on the fishers and their means of harvest. In capture fisheries, it is rare that the resource is completely destroyed. Therefore, once gear has been replaced, production can restart. This has significant implications for food production chains, food security and broad livelihood rehabilitation of affected people and those dependent on the sector for employment and food.

In assessing damage and needs relating to capture fisheries gear, it is important to understand the complexity of the affected fishery and the stakeholders involved. Bearing this complexity in mind, the following sections outline the main technical considerations relating to assessment of damage and needs in the capture fisheries sector. These have been arranged as follows:

- fishing gear,
- fishing vessels,
- engines.

The technical guidance is accompanied by appropriate photographs, dimensions and geographic locations that may be encountered during a damage and needs assessment.

A2.2 TECHNICAL CONSIDERATIONS FOR THE DAMAGE AND NEEDS ASSESSMENT (FISHING GEAR, BOATS AND ENGINES)

A2.2.1 Fishing gear

Fishers use a very wide variety of fishing gear. Local variations are found by area, season and target species. It is not possible to provide a detailed description of each type, but the following key categories should allow gear classification and description based on local types.

Fishing gear can be classified by type and/or by the target species of fish. Sometimes, gear design may be linked to the type of fishing boat. The FAO fish capture technology website at www.fao.org/fishery/fishtech/search/en is a key resource for identifying and understanding the different types of fishing gear. The main types of fishing gear are shown in Figure A2.1.

FIGURE A2.1 Broad types of fishing gear

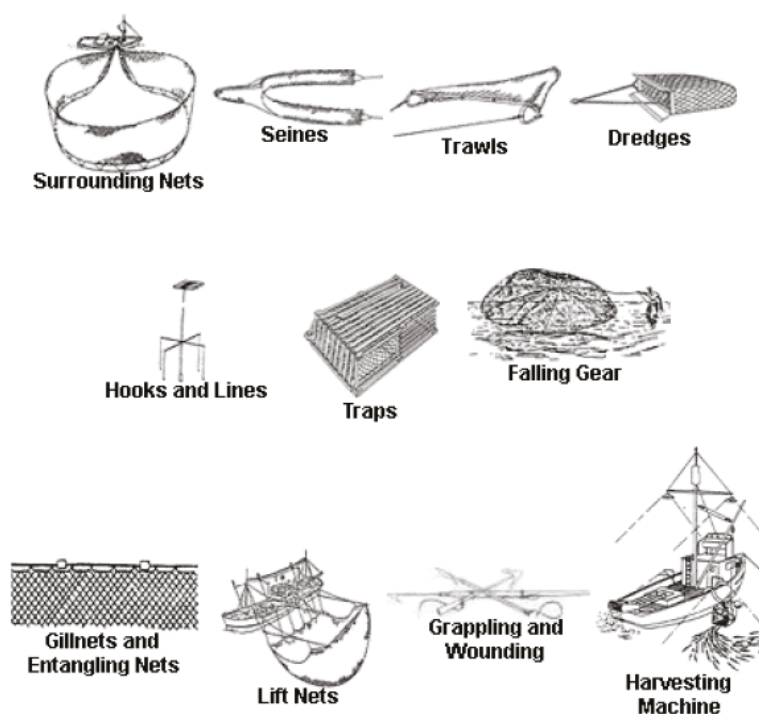

A2.2.2 Assessing fishing gear

In practice, a wide variety of local and traditional designs of gear or adaptations to local needs will be found. Some key considerations during the assessment of gear include:

- Collect as much **local information** on fishing gear, boats and engines and as accurately as possible.

- When asking for technical specifications of fishing gear/boats, one should consider the **existing regulatory frameworks** (prohibited gear types and fishing methods, and closed seasons on certain species). **Photographs and detailed measurements** help to make the specifications clear.

In all aspects of the assessment, understanding the technical specifications and measurements is essential. The following sections provide guidance on the most common measurements and specifications needed.

A2.2.2.1 Netting materials, ropes and mending twines

In general, all modern netting materials, ropes and mending twines are made from the following materials: PA, PES, PP, PE, PVA. Depending on the fishing gear, different material or combinations thereof are used. The following is a brief description of their physical properties.

- PA, also called nylon polyamide, is a synthetic fibre that sinks as it is denser than water (density = 1.14), with a good breaking strain and abrasion resistant. Its other properties are very good elongation and elasticity.
- PES, also called polyester, is a synthetic fibre that sinks as it is denser than water (density = 1.38), with good breaking and elasticity but poor elongation as it does not stretch.
- PP, also called polypropylene, is a synthetic fibre that floats as it is less dense than water (density = 0.91–0.92), with a good breaking strain and abrasion resistant.
- PE, also called polyethylene, is a synthetic fibre that floats as it is less dense than water (density = 0.94–0.96), with good resistance to abrasion and good elasticity.
- PVA, also called polyvinyl alcohol, is a synthetic material that sinks as it is denser than water (density = 1.30–1.32) with good resistance to abrasion and good elongation.

A2.2.2.2 Net measurements

When specifying net materials, it is important to note the following (for lift net, cast net, gillnet, traps, beach seine, etc.):

- The type of material, identification (PA, PES, PP, PE) and whether material is available locally.
- The type of twine (multifilament braided or twisted, monofilament, multi-monofilament, monotwist).
- Twine size, measurement, which is usually Denier and is always designated by the 210d/ at the beginning. For example, here are some different common twines sizes: 210d/6, 210d/9, 210d/12, 210d/15, 210d/18 – the smaller the last number, the thinner the twine. Therefore, 210d/6 is thinner than 210d/12.
- Monofilament twines are specified by the diameter of the monofilament and it is usual to specify it in millimetres. Example: PA monofilament × 0.40 mm diameter.

- The colour of the netting material (green, blue, white, brown, red, etc.).
- Mesh size is the length of mesh for knotted netting. It is the distance between two opposite knots in the same mesh when fully extended (Figure A2.2) – to be given normally in stretched mesh. Take the average of several meshes as they are sometimes stretched or shrink, especially in nets made manually. The stretched mesh size is specified in millimetres or inches. It is important to specify the stretched mesh size and not the half mesh size.

FIGURE A2.2 Mesh size measurement

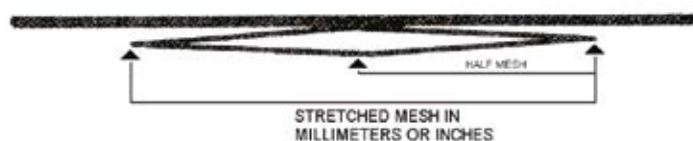

- The depth of the net is specified by the number of meshes deep from the float line to the leadline of the given mesh size. Figure A2.3 illustrates how the meshes are counted. Different net panels are different numbers of meshes deep depending on the type of fish, the depth of water, the mesh size and the fishing practices in the area; this is why it is important to count the number of meshes. Simply measuring the height of the net panel is not enough as the height will vary with the way that the net is attached to the float and lead lines.

FIGURE A2.3 How to count the depth of the net

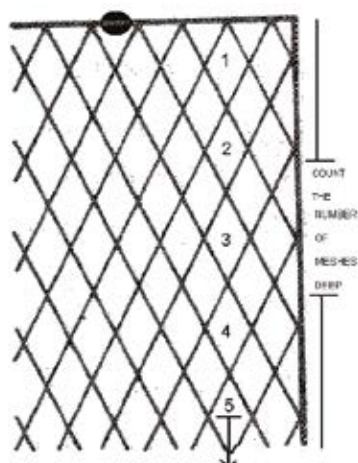

- Measure: Length of net (stretched) is determined by the length of the net panel (specified in metres) and is the entire horizontal length of the net panel stretched out.

A typical specification for a net panel will be as follows:

Material type (PA, PES, PE,) × type of twine (monofilament, multifilament, multi-monofilament) × stretched mesh size (in millimetres) × meshes deep (number) × length of net panel (metres)

A2.2.2.3 Fishing floats

Fishing floats comes in many different shapes, sizes, materials, buoyancy, hole sizes and even colours. These also need to be correctly specified in order to obtain the correct material. Correct specifications will save the field worker much time as there will be fewer queries from the supplier. Floats have many different uses and are specific to different fishing methods. For example, floats used on seine nets are very different from those used on deep-water gillnets.

- Floats should be specified by their **shape**, their **diameter**, their **length**, and the **diameter of the hole** through the rope of line passes and, if possible, their flotation/buoyancy.
- The estimate of the buoyancy of a float can be calculated by the following formula:

$$\text{Buoyancy in grams} = 0.55 \times \text{Length (cm)} \times \text{Diameter (cm)}^2$$
- There are many different types of float (see Figure A2.4), for example:
 - Different shapes, e.g. can, oval, egg, cigar, rectangular.
 - Different materials, e.g. PVC or expanded (polyvinyl chloride), hard plastic, polystyrene, rubber to be inflated or aluminium.
 - For attaching to the net, they may have holes through the centre or through the sides, or eyes to fasten (sometimes removable). **The hole diameter is important.**
- With floats, it is best to take a digital photograph and make the measurements to accompany the photograph to the supplier.

FIGURE A2.4 Types of float

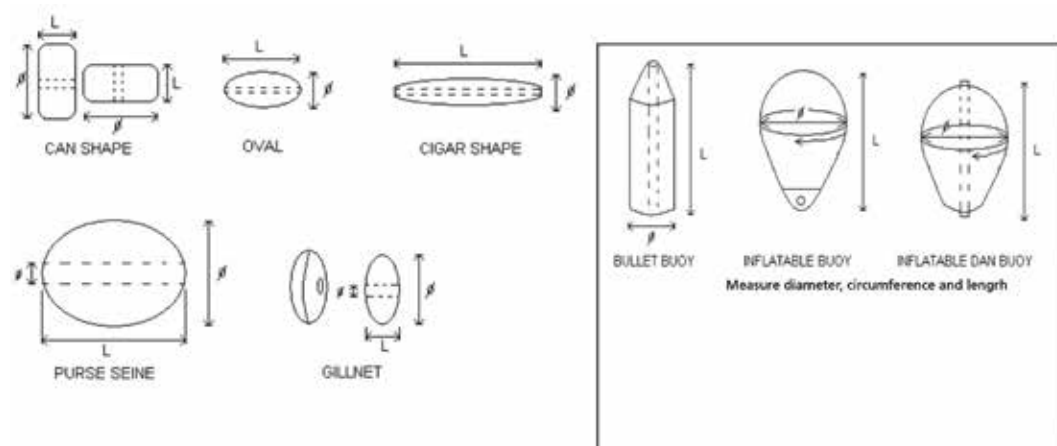

A2.2.2.4 Fishing weights

Fishing weights are usually made of lead, but other materials such as steel and concrete are also used. Weights come in many different shapes and sizes and vary depending on the application (see Figure A2.5).

Weights are used on different nets and together with hooks to fish on the bottom.

Key considerations include:

- The weights come with holes through which the rope, twines or fishing line is threaded. Therefore, it is important to specify the hole diameter, the shape of the weight, its size and the weight in kilograms or grams.

FIGURE A2.5 Types of fishing weights

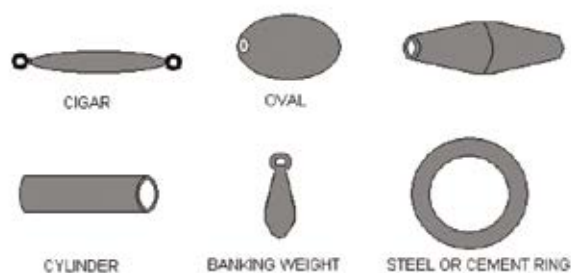

FISHING WEIGHTS OF DIFFERENT SHAPES AND WEIGHTS

A2.2.2.5 Leadline

Leadline is a rope with lead pellets integrated into the centre of the rope by a special manufacturing process. When using leaded line, one does not have to buy the rope and lead separately as the rope is already weighted. Key considerations include:

- Before purchasing this type of material, it will be necessary to calculate the weight required per unit length of the net. Leadline is specified in kilograms per 100 m.

A2.2.2.6 Floatline

Floatline works on the principle of integrating the floating material into the rope. The floats are woven into the rope by special manufacturing process. Key considerations include:

- Before purchasing this type of material, it will be necessary to calculate, together with the fisher, the buoyancy requirements. The buoyancy of floatline is specified by the number of kilograms force per 100 m of floatline.

A2.2.2.7 Constructing and mending nets

Mending and mounting are essential for constructing the fishing gear. The twine for mending should be the same specifications in size and material as the twine that the fishing net panel is made of. Mounting and mending twines are specified by the type of material, that is (PA, PES, PP, PE), the type of twine, that is (multifilament braided or twisted, monofilament, multi-monofilament, monotwist), the twine size or Denier Rtex, Tex, 210d/, etc., the colour and the weight per spool of the desired twine.

Key considerations include:

- The following are typical examples of the specifications for mending twine:
 - Mending twine PA × multifilament twisted × white × 210D/12 × 500 g per spool
 - Mending twine PA × monofilament × green × 0.50 mm × 500 g spool
- Fishers may require different diameter twines for the same net – one size for mounting the net and another size for repairing or mending the net.
- Ropes are manufactured with different synthetic materials. These materials are the same as those used in the manufacture of the net panels and the twines (described above). The materials commonly used are PA, PE, PES, PP, etc.
- It is essential to specify the rope diameter (usually in millimetres or in inches). Ropes come as twisted or braided and this should also be specified. When ordering or specifying ropes, it is necessary to specify the colour and the length per coil. An example of a typical rope specification is:
PE × 8 mm × twisted × blue × 200 m per coil

A2.2.2.8 Other gear types

Pots and traps. Normally, these are locally made. Key considerations include:

- Provide a list of material necessary for construction.
- If ready made, provide a detailed drawing or photograph with the measurements.

Hooks. There are many different types of hooks and all with different sizes and by different manufacturers. There are also imitations on the market and the field worker is cautioned against buying imitations. Key considerations include:

- When specifying hooks, avoid (if possible) giving the model number on the box as this often means different things to different procurement organizations and manufacturers. Figure A2.6 shows the different important measurements that should be taken when specifying fishing hooks. Give the dimensions, shank (length) and bend (length). Also describe colour, extremity (flat or twisted), with eye or without (flattened). Where a number is used, also specify manufacturer and quality, e.g. Mustad S.2330DT N° 5. If possible, provide samples and photographs with the dimensions.

FIGURE A2.6 Hook measurements

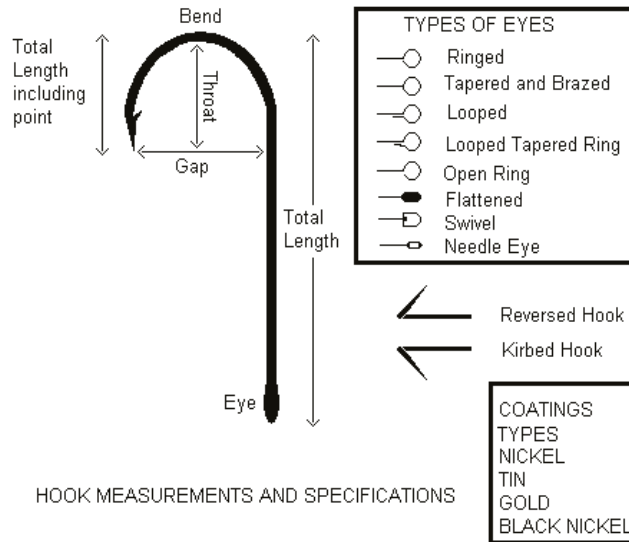

Swivels and snaps. These come in different shapes, sizes and materials. Key considerations include:

- The type should be specified. Swivels are sized by number, #1, #5, #8, for example, or they may be designated as 1/0. The numbering system used depends on the markets where they are made.
- In all cases, the field officer should try to provide samples (or sketches or photocopies) or manufacturers' numberings and codes. Figure A2.7 shows some typical swivel types used in small-scale fisheries.

FIGURE A2.7 Typical swivel types used in small-scale fisheries

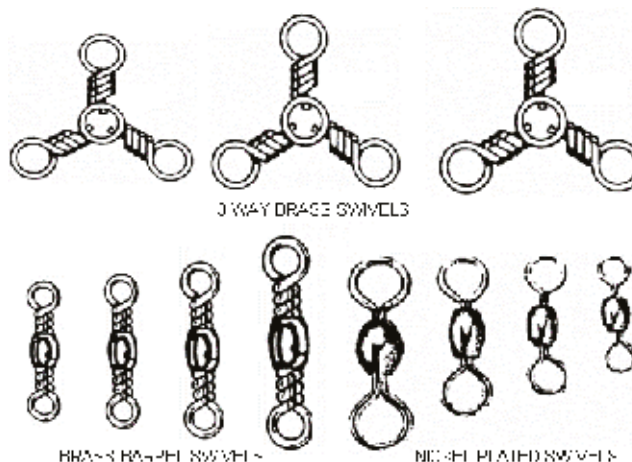

A2.2.3 Fishing vessels

Fishing vessels come in a very large variety of shapes and sizes. In any particular country or location, these craft have been adapted to the existing physical conditions, and the builders take into consideration the available materials, local boat building customs and climatic conditions. The designs evolve to meet the aquatic resources and market conditions. Therefore, it is not possible to give one solution that suits all purposes.

In needs assessment, regarding boats, it is of paramount importance to understand the different types of craft, how they are used, the resource that they target, and the fishing gear that they deploy. This is best done by the involvement of an expert in fisheries, naval architecture and/or boatbuilding from the outset. However, because it may take time to bring this expertise into the field, the initial rapid assessment will need to describe in broad “local” terms what vessels are used and how they are classified locally. Because of the many types of boats found, the use of a local classification is essential to ensure that damage is assessed and beneficiaries’ needs are addressed. Local fisheries officers can assist with the classification and may have a licensing or registration system in place.

Boats are classed into two main categories: (i) decked, and (ii) undecked. They may also be classified as to whether they are mechanized or not (engine or no engine) or according to the type of fishing they carry out (for example, multiday, day or deepwater).

Guidance on assessing fishing vessels is included below:

- **Construction materials:** Fishing boats can be made of wood or plywood, fibreglass (sometimes called GRP or FRP [glass reinforced plastic or fibre reinforced plastic]), aluminium, steel and ferrocement. In the needs assessment, attention should be paid to the name of the type of wood (Latin name if possible) especially if it is found locally. In some cases, similar substitutes may not have the same characteristics of resistance to rot or availability (timber resources for the particular wood may be in short supply or come from long distances). The assessment officer should check the availability of this type of wood
- **Manufactured boats:** If the boats are manufactured in series, such as in the case of many GRP production boats, then the field office should obtain the manufacturer’s name, specifications, brochures, drawings, etc. if available.
- **Hull shape/form:** The hull of the fishing vessel may be flat-bottom, v-shaped, rounded or it may be a dug-out log.
- **Hull measurements:** Figure A2.8 shows the different basic hull measurements that should be taken during the assessment.

FIGURE A2.8 Typical measurement of boats to be taken during the needs assessment

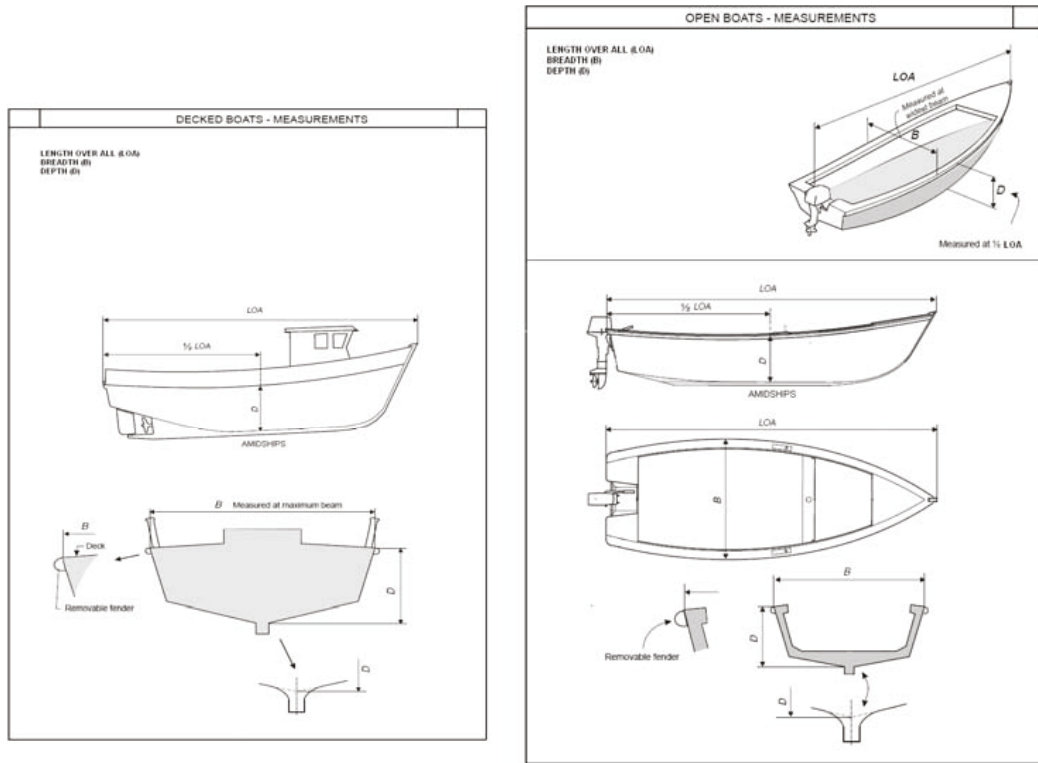

A2.2.4 Propulsion, machinery and engines

Fishing boats are mainly powered by inboard or outboard engines, sails or hand (or combinations thereof). Engines may use either petrol or diesel fuels and, in some countries, kerosene is also used (rarely electric motors).

Larger boats may have ancillary equipment for hauling gear, which should also be noted.

In a needs assessment, it is important to specify the following for propulsion systems (the following is a checklist to assist the field officer:

A2.2.4.1 Inboard engines

- Type of fuels include petrol, kerosene and diesel.
- Engine make, model, horsepower and series number. Engine manufacturers make many different series of the same engine for different countries and working environments.
- Availability of reliable engine and spare parts supplies and repair workshops, in the area or close by. Involve the local accredited engine manufacturer's representative.
- Exhaust type – wet or dry.

- Gearbox make, model, gearbox ratio.
- Propeller (which is either left-handed or right-handed), propeller diameter and pitch should be noted as well as the material that the propeller is made of. To measure the diameter, measure the radius of the propeller from the shaft centreline to the tip of one of the blades.
- Propeller shaft – shaft length, shaft diameter, shaft coupling diameter and key size and construction material.
- Propeller – propeller diameter, pitch and construction material.
- Stern tube – specify the length, internal diameter, thickness and details of the sealing and lubrication (water or oil).
- Water cooling pump size and capacity (in litres per minute).
- Starting mechanism – electrical or manual or air (not very common on small boats).
- Electrical charging – battery size in ampere hours (AH) and alternator capacity, make and charging amps including voltage regulator.
- Bilge pumps for watertight compartments such as engine room, fish hold and accommodation spaces. The capacity, powering arrangement (manual, electrical, drive belts).

A2.2.4.2 Outboard engines

These are very common on small boats and provide an effective power source. Some boats may have an outboard engine for emergency purposes. Locally manufactured or adapted engines such as “longtails” (Plate A2.1) can be used.

When specifying outboard engines, specify as per the following checklist:

- Engine make, model, horsepower and series. Engine manufacturers make many different series of the same engine for different countries and working environments.
- Whether the engine uses a combination fuel tank or just one fuel. Some engines use gasoline to start and then, once the engine is warm, the fuel is switched to kerosene.
- Take a photograph of the propeller types used with each engine.

PLATE A2.1 Outboard and “longtail” engines (Viet Nam).



A2.2.4.3 Sails

Sails may be used as the principal of auxiliary means of propulsion.

- Draw the sail and the dimensions, and take a photograph of a similar type of boat with the sail rigged.

A2.2.4.4 Safety equipment and engine spares

- Record all safety equipment on board, such as:
 - lifejackets, one for every person on board (SOLAS certified lifejacket);
 - bailers, at least two;
 - anchor adequate for the type of sea bottom and anchor rope in sufficient quantity for the normal operational depth of water;
 - oars or other manual propulsion such as paddles;
 - a sharp knife;
 - mirror;
 - hand flare (flares);
 - VHF radio with antenna;
 - flotation device ring buoy for “man overboard”;
 - buoyant apparatus;
 - fire extinguisher (extinguishers) and or fire bucket;
 - electric lantern or torch with spare batteries.
- Record also the number of crew that normally fish on the vessel.
- Record spare parts and materials – inboard diesels such as:
 - fuel and oil filters including gearbox oil filters;
 - alternator;
 - water pump;
 - spare starter;
 - alternator and water pump belts;
 - spare hoses and hose clamps;
 - electrical wires and tape;
 - grease and engine oil;
 - tools for the engine and for deck machinery;
 - ancillary equipment (electrical tape, wire, electric connectors, glues, fuses, spare bulbs);
 - spare engine, hydraulic and gearbox oil;
 - instruction manuals of the equipment on board;
 - spare water pump impeller and seal kit;
 - fuel and oil filter spanner;
 - spare propeller packing gland material;
 - 30 percent more fuel than needed for the journey.
- Adequate engine spares – outboard engines, such as:
 - spare new (not used) spark plugs and good plug spanner;
 - pliers and set of flat and Phillips (cross) screwdrivers;
 - spare starter cord;

- spare propeller pin;
- spare propeller split pin;
- 30 percent spare fuel and oil mixture;
- feeler gauge to gap the spark plugs;
- emergency stop.

A2.2.5 Additional information regarding vessels and engines

Vessel ownership: The pattern of ownership of the vessel should be outlined. In many cases, owners do not operate the boat; investors may own shares and lease the boat to skippers. The approximate breakdown of the income from catches should be noted (e.g. owner 50 percent, skipper 25 percent, and crew 25 percent). In this respect, the number of crew should be recorded.

Boatyards: An initial assessment should outline the numbers and location of boat builders or suppliers.

Data collection: It is advisable to talk initially to the department of fisheries, ministry of fisheries and any agencies that may have vessel numbers or registries for the affected area. If a vessel or fisher registry has been maintained, this can save a great deal of time. However, in some countries, vessel registration is with ministries other than fisheries (for example, the ministry for transport). These registries may collect data at district/local level. Local fishers organizations (cooperatives/associations) may also maintain lists of members).

There may be national yearbook or statistical data. It is advisable also to talk to local experts such as fisheries officers and fisherfolk and/or fishers organizations in order to form an overall picture of the fishing activities and practice in the area.

Other sources of data are:

- FAO Representative, other UN Agencies involved in fisheries (such as UNDP, UNICEF) and the International Federation of Red Cross and Crescent Societies (IFRC);
- representatives of government institutions, especially at local level (e.g. local fisheries officers if any), fisheries administrations, coastguards, marine department;
- fish farmers, fisherfolk, representatives of fishery communities, fisherfolk associations and other local and international NGOs;
- academics, researchers, universities.

This will also allow the main fishing approaches, vessels and gear to be identified. Fisherfolk can be asked to describe the fishing gear they are using in detail (maybe even draw the fishing gear) if they are not able to recognize it. Local names for boat and fishing gear (if any) should be specified, as should the season when the latter are used. It is preferable to use international units. Sometimes, fisherfolk use different gear according to season.

Secondary information sources:

- Fishery Country Profiles prepared and published by FAO's Fisheries and Aquaculture Department (www.fao.org/fi/fcp/fcp.asp). These profiles provide a general snapshot of the fisheries sector in a country. However, small-scale fisheries within a country are very diverse and are often area- or culture-specific.
- Fisheries Global Information System (FIGIS) prepared by FAO's Fisheries and Aquaculture Department (www.fao.org/figis/). FIGIS provides information on fishing technologies.
- National disaster coordination structures (local and national levels).
- The FAO Fisheries and Aquaculture Department library is available to provide information. The librarian can be contacted at: FI-library@fao.org

Where national data are available, then these should be scanned/photographed as reference. A summary of the gear, vessels and engines could be included.

In coordination with institutions working locally, an affected community (or village) should be selected for a visit.

Other key considerations/actions:

- Where possible, a chart of the area should be used to determine the location of the fishing communities, nature of the surrounding area, local names, mean water depth, etc.
- Information about the impact of the disaster on fishing systems (fishing gear/boats, processing equipment/installations, port and landing facilities, store rooms, salt pans, transportation and fish production), the likely impact on fisheries production, the impact of any loss in production on food supply, and other impacts on the affected groups.
- Information on affected groups with special reference to low-income groups and gender issues: who fishes / who collects seashells? Full-time? Part-time? How have they been affected by disaster (income losses, dependence on fish for consumption)? What are their survival/adaptation strategies (i.e. do they have access to food, money and/or assets)?
- Identify fishing and fish processing methods.
- Identify what the disaster reveals in terms of ongoing or additional problems (e.g. boat safety). It is important at this stage to identify ongoing problems in an effort to define interventions that will reduce future risks (e.g. training options, improvement of fishing gear).
- Gather detailed information, sketches, specifications and approximate pre-disaster and current local prices and availability of the most commonly used boats, fishing gear and other equipment, and prepare a list of recommended inputs.
- Identify (in close collaboration with the local/district authorities) mechanisms by which inputs can be distributed to the neediest beneficiaries.

- Become informed about government development plans and strategies relating to the sector, and make contact with the local, regional and national fisheries departments.

Tables A2.1–A2.6 provide some examples of the types of data and synthesis that can be collected during the assessment. Note that because of the diversity of gear, boats and fisheries, it is difficult to standardize a format.

TABLE A2.1
Narrative description of key fishing elements

Fishery and/or Province/area (using national/local classifications)	Type of vessel and local name. Construction type (types) Crew number	Length, width range (and GT)	Engine/propulsion options	Principle and secondary gear	Fishing method and target species	General ownership/operation	Value US\$
1. Vessel 1 Fishery and province used in	Narrative description of vessel (decked/undecked) Wood, steel, GRP	L, W, D or 10 GT	Inboard, outboard Sail Row	Trawl Purse seine etc.		Owner-operated skipper	
2. Vessel 2 Fishery and province used in	Narrative description of vessel (decked/undecked) Wood, steel, GRP						
3. etc.							

Once a general description of the fishery has been prepared, summaries of damage should be made up for impacts at local/district level. For the initial rapid assessment, these may be at a general level. However, more detailed assessments may be possible at household/individual level if government registries have been maintained.

TABLE A2.2

Example of a narrative descriptions from fisheries

JAFENA
SPECIFICATIONS OF FISHING GEAR

COLLENETS

Setting

Material - Polypropylene water resistant
 Color - White
 Length - 2500 meters
 Depth - 350 meshes
 Mesh size (overall mesh) - 38 mm (1.5")
 Trawl size - 2162 (2-ply)
 Type of knot - Single
 Direction of knot - Deftwise
 Strainage top and bottom - 400%

Reels

Clear line - Polyethylene natural PE 5 mm diameter - 42 mm
 Zinker line - Polyethylene natural PE 5 mm diameter - 42 mm

Floats

SPAC - clear float type PSB 180mm (7") - 5 pieces
 Replicas float cylindrical type B175, 180mm x 160mm - 2 pieces

Stoppers

Cylindrical counter pieces

Heads of fish - 21 rats

Trawl components - Rattles and others

Fishing units - 18'x19' FRP Box

Table 13. Net Loss and Retention Prices of Fishing Gear

No.	Gear	Material	No. of Unit	No. Ret per Unit	Current Price per Unit	Retains Price for P.G	APPR PRICE IN US\$
1	Clear net	Polypropylene	55	100%	200,000	500,000,000	5,714
2	Shrimp net	Polypropylene	2,750	75.50%	21,270,000	40,000,000,000	1,247,467
3	Shrimp gill net	Polypropylene	250	10.50%	16,500	10,000,000	29,157
4	Line net	Polypropylene	3,250	82.00%	20,250,000	30,000,000,000	1,250,220
5	Line net (10-1)	Polypropylene	4,450	67.50%	2,385,000	14,000,000,000	4,325,767
6	Line net	Polypropylene	450	7.00%	21,000,000	20,000,000	28,500
7	Line net	Polypropylene	50	100%	20,000,000	20,000,000	10,500
8	Line net	Polypropylene	410	0.00%	10,000,000	0,000,000,000	0,000,000
9	Line net	Polypropylene	150	1.00%	10,000,000	10,000,000	1,470,000
10	FRP BOX		12,247	50.50%	18,645	25,000	7,774,714
11	SPAC - clear float	Polypropylene	1,125	100%	10,000	2,000,000,000	44,444
12	Shrimp gill net	Polypropylene	250	75.50%	1,275,000	1,000,000,000	24,467
13	Shrimp gill net	Polypropylene	180	27.50%	5,550,000	100,000,000	49,125
14	Shrimp gill net	Polypropylene	180	2.00%	2,000,000	20,000,000,000	41,000
15	Line net (10-1)	Polypropylene	2	100%	1,750,000	1,750,000	4,775
16	Line net (10-1)	Polypropylene	1,250	10.00%	2,125,000	2,125,000,000	118,111
17	Line net	Polypropylene	450	97.00%	10,000,000	11,800,000,000	1,400,222
18	Line net	Polypropylene	50	0.50%	10,000,000	1,000,000,000	100,000
19	Line net	Polypropylene	10	100%	10,000,000	10,000,000,000	55,000
20	Line net	Polypropylene	12	50%	21,000,000	20,000,000,000	29,157
21	FRP BOX		0,750	100.00%	24,750,000	25,000,000,000	2,100,000
	TOTAL		10,316	67.80%		186,028,833,162	18,388,888

Fishing Boats

Most boat owners in the capture fishery are characterized by their individuality. The table below shows the breakdown number and by type of propulsion units used on the fishing fleet by district before the tsunami. The information is from MMAF data in 2003.

Table 2 Breakdown of Boats by propulsion type by District before Tsunami

No.	District	No engine	Outboard	In Board Engine
1	Sumbawa	680	430	7
2	Acch-Sangat	400	112	307
3	Acch-Selatan	2,265	628	474
4	Acch-Tengah	317	109	2,304
5	Acch-Barat	645	108	87
6	Acch-Barat	270	475	202
7	Pala	647	280	350
8	Banawa	945	814	524
9	Acch-Melayu	230	292	87
10	Banda Aceh	36	80	136
11	Subang	635	80	546
12	K.Lhokomawe	-	-	-
13	Kota Lingsar	-	-	-
14	Acch-Barat Utara	560	163	140
15	Acch-Jaya	-	-	-
16	Nagah Raya	-	-	-
17	A. Taraman	302	326	628
	TOTAL	8,338	3,869	6,279

Source: MMAF Database

Fishing boats Lost and damaged

Inboard Engine Boats

The table below shows the breakdown of inboard engine boats lost and damaged broken-down by district, coastal zone and comparison to pre tsunami numbers.

Table 9 Number Inboard of Lost, Damaged and Remain

No.	DISTRICT	BEFORE TSUNAMI	Lost		Damage		Remain
			No.	%	No.	%	
1	Banda Aceh	206	145	56.1	25	13.1	36
2	Acch-Barat	341	295	86.5	45	13.1	46
3	Pala	478	78	16.3	100	20.9	300
4	Banawa	737	476	65.5	195	27.1	76
5	Acch-Utara	911	321	35.2	171	18.8	419
6	Lhoksumawe	11	102	88.9	8	7.1	1
7	Acch-Tengah	1,540	-	-	527	34.3	993
8	Langsa	427	2	0.5	-	-	425
9	Acch-Taraman	950	12	1.3	21	2.3	917
10	Subang	144	20	13.9	45	31.3	79
11	FRP BOX	3,697	1,500	40.5	1,040	28.1	2,157
12	Acch-Jaya	257	84	32.7	0	0	173
13	Acch-Barat	515	230	44.8	217	42.1	67
14	Nagah Raya	167	156	93.2	0	0	11
15	Acch-Barat	172	79	45.9	15	8.7	78
16	Acch-Selatan	483	117	24.2	85	17.6	281
17	Acch-Sangat	379	0	0	0	0	379
18	Sumbawa	1,700	230	13.5	219	12.8	1,251
19	FRP BOX	1,000	802	80.2	590	59.0	1,908
	TOTAL	9,889	2,411	24.4	1,876	18.9	5,602

Fishing Gear

Total fishing gear inventory in year 2003 noted 26,088 units which consist of prawn seine 310 (1.22%), shrimp net 1,633 (6.20%), purse seine 1,800 (6.90%), gill net 6,494 (24.55%), lift net 933 (3.58%), line fishing or mini long line 9,940 (38.14%), trap 1,851 (7.09%) and other gears 1,110 unit (4.25%).

Table 3 Type and number of Fishing Gear per District before Tsunami in units source MMAF

District	Shrimp net	Purse seine	Rig	Silhat	Lift net	Hook line	Trap
Sumbawa	-	1	41	220	-	1,132	205
A. Senggar	-	26	183	110	218	969	240
A. Subuloh	-	70	150	1,150	100	1,100	304
A. Satar	-	271	231	1,000	45	30	150
A. Sawai	-	5	2	1,000	11	483	240
A. Bontol	-	107	100	30	104	280	240
Pala	-	10	130	800	80	90	140
Banawa	8	10	10	10	10	10	10
A. Daya	300	10	10	10	10	10	10
B. Acch	-	47	1	11	-	-	-
20000	-	11	7	37	1	38	-
21. Kabupaten	-	-	-	-	-	-	-
Kota Langsa	-	-	-	-	-	-	-
Acch-Lingsar	-	10	113	730	74	1,100	204
Acch-Barat	-	-	-	-	-	-	-
Acch-Tengah	-	-	-	-	-	-	-
A. Taraman	-	10	113	730	74	1,100	204
Total	310	1,633	1,800	9,940	933	9,940	1,851

TABLE A2.3

Summary damage assessment for locality/district

Locality details	Province (name)	District (name)	Subdistrict (name)
Name			
Map ref/GPS	Date of visit		
Vessel by type (see above)	Before (and units)	Damage (units lost)	Needs
Vessels			
Vessel 1.	500	200/50	200
Vessel 2.			
Engines			
Vessel 1. Outboard			
Vessel 2. Inboard			
Gear types			
Vessel 1. Gear Type 1			
Vessel 1. Gear Type 2.			

TABLE A2.4

Summary damage and needs value assessment for vessels/gear and engines

District name	Province Name	Vessel type	Units lost	Before	Damage	Replacement estimate
				Value	Value	Value
District A	Province B	Vessel 1.		US\$	US\$	US\$
		Vessel 2.				

TABLE A2.5

National summary

Total rehabilitation	Number damaged cost	Rehabilitation cost
Vessel type 1	US\$	US\$
Vessel type 2	US\$	US\$

TABLE A2.6

An example of the information that a detailed assessment can provide: loss and damage in Aceh, Indonesia

Nr	NAME			Name of Fisherman			Boat								Engine								
							Type	Status	Crew	Size (M)				Lost (L), Damage (D) Light Dmg (LD), Good (G)	Specification					Lost (L), Damage (D) Light Dmg (LD)			
Nr	District	Subdistrict	Village	First	Last	Age	IB/OB/BWE	O	J	R	NR	L	W	D	GT	L/D/LD/G	Name	HP	Fuel	As	Gear Box	Prop	L / D / LD
1	AB	Johan Pahlawan	Padang Seurahet	TAUFIK		20	IB	O	-	-	2	6	1.6	0.8	1.4	L	R	5.5	B	0.8	--	8/7	L
2	AB	Johan Pahlawan	Padang Seurahet	SAIFUL		31	IB	O	-	-	2	8	1.5	0.8	1.6	L	DP 8	8	D	1	--	8	L
3	AB	Johan Pahlawan	Padang Seurahet	HERMAN		31	IB	CO	-	-		9	1.8	0.9	2.7	L	DP 12	12	D	1.3	1 : 2.5	12	L
4	AB	Johan Pahlawan	Padang Seurahet	SULAIMAN	ABAS	34	IB	C	-	-	3	13	2.5	0.9	5.5	L	DP 16	16	D	1.3	1 : 2.5		L
5	AB	Johan Pahlawan	Padang Seurahet	YUSPANDI		42	IB	CO	-	-	2	14	2.1	0.9	5.0	L	DP 16	16	D	1.3	1 : 2.5	22	L
6	AB	Johan Pahlawan	Padang Seurahet	MAKSYAH		30	IB	O	-	-	3	11	1.8	1	3.7	L	DP 16	16	D	1	1 : 2.5	12	L

Fishing Gear																						
Kind of	Nr.Set								Hook and Line												Lost (L), Damage (D) Light Dmg (LD)	
	Set	Size of Net			Size /Rope				Long line				Trolling			Handline						
FG	Nr. Set	L	D	Mesh Size	Name	Float Rope	Foot Rope	Sinker	Kind of	Main Line	Branch Line	Nr of Hook	Size of Hook	Main Line	Branch Line	Nr of Hook	Size of Hook	Main Line	Branch Line	Nr of Hook	Size of Hook	L/D/ LD
DGN																						
BLL																						
BGN	200			2					BLL													
TR																						L
																						L
BLL																						

A2.2.6 Background reading

- Ben-Yami, M.** 1976. *Fishing with light*. FAO Fishing Manual. UK, Fishing News Books Ltd. 150 pp.
- Ben-Yami, M.** 1980. *Tuna fishing with pole and line*. FAO Fishing Manual. UK, Fishing News Books Ltd. 150 pp.
- Ben-Yami, M.** 1987. *Purse seining with small boats*. FAO Training Ser. 13. Rome, FAO. 97 pp. (in English, French and Spanish)
- Ben-Yami, M.** 1988. *Attracting fish with light*. FAO Training Ser. 14. Rome, FAO. 72 pp. (in English, French and Spanish)
- Ben-Yami, M.** 1994. *Purse seining manual*. FAO Fishing Manual. Rome, FAO, and UK, Fishing News Books Ltd.
- Ben-Yami, M., comp.** 1989. *How to make and set FADs (fish aggregating devices)*. FAO Training Ser. 15. Rome, FAO. 68 pp. (in English, French and Spanish)
- Bjarnason, B.A.** 1992. *Handlining and squid jigging*. FAO Training Ser. 23. Rome, FAO. 62 pp. (in English, French and Spanish). Bottom Trawls for Small-Scale Fishing; Supp.1: Adaptation for Pair Trawling. FAO Fish. Tech. 189 (in English)
- Caddy, J.F. & Bazigos, G.P.** 1985. *Practical guidelines for statistical monitoring of fisheries in manpower limited situations*. FAO Fisheries Technical Paper No. 257. Rome, FAO. 86 pp. (also available at www.fao.org/docrep/003/T0011E/T0011E00.HTM).
- FAO.** 1974. *Otter board design and performance*. FAO Fishing Manual. UK, Fishing News Books Ltd.
- FAO.** 1978. *FAO catalogue of fishing gear designs*. London, Fishing News Books Ltd.
- FAO.** 1987. *FAO catalogue of small-scale fishing gear*. Second edition. London, Fishing News Books Ltd. (multilingual)
- FAO.** 1993. *Report of the Expert Consultation on the Marking of Fishing Gear, Victoria, British Columbia, Canada, 14–19 July 1991. Rapport de la Consultation d'Experts sur le Marquage des Engins de peche, Victoria, Colombie britannique, Canada, 14-19 juillet 1991. Informe de la Consulta de Expertos sobre el Mercado del Equipo de Pesca, Victoria, Columbia Británica, Canadá, 14-19 de julio de 1991*. FAO Fisheries Report No. 485. Rome/Roma. 42 pp. (also available at www.fao.org/docrep/010/t0759t/t0759t00.htm).
- FAO.** 1993. *Recommendations on the Marking of Fishing Gear Supplement to the Report of the Expert Consultation on the Marking of Fishing Gear Victoria, British Columbia, Canada, 14–19 July 1991*. FAO Fisheries Report No. 485 Suppl. Rome.
- FAO.** Dan Davey Myanmar . Report on visit to Myanmar to prepare designs and step-by-step construction manuals for the construction of small multi-purpose vessels under project OSRO/MYA/805/SWE
- Fisherman's pocket book (English version: Fishing News Books Ltd; UK; French version: Ed. Lavoisier, Paris, France; Spanish version: Ediciones Omega, Barcelona, Spain; Portuguese version: EDITAMAR, Lisboa, Portugal) Fisherman's Workbook FAO/Blackwell Publishing Ltd <http://www.fishknowledge.com/fnbbook.asp?File=677>

- Fridman, A.L. & Carrothers, P.J.G.** 1986. *Calculations for fishing gear designs*. FAO Fishing Manuals. Farnham, UK, Fishing News Books Ltd.
- George, J.P.** 1993. *Longline fishing*. FAO Training Ser. 22. Rome, FAO. 81 pp. (in English, French and Spanish)
- Hamabe, M., Hamuro, C. & Ogura, M.** 1982. *Squid jigging from small boats*. FAO Fishing Manual. Farnham, UK, Fishing News Books Ltd. 74 pp.
- Karlsen, L. & Bjarnason, B.** 1987. *Small-scale fishing with driftnets*. FAO Fisheries Technical Paper No. 284. Rome, FAO. 64 pp. (in English, French and Spanish)
- Klust, G.** 1982. *Netting materials for fishing gear*. Second edition. FAO Fishing Manual. UK, Fishing News Books Ltd. 175 pp.
- Klust, G.** 1991. *Fibre ropes for fishing gear*. FAO Fishing Manual. UK, Fishing News Books Ltd. 216 pp.
- Libert, L., Maucorps, A. & Innes, L.** 1987. *Mending of fishing nets*. FAO Fishing Manual. UK, Fishing News Books Ltd. 122 pp.
- Nédélec, C. & Prado, J.** 1990. *Definition and classification of fishing gear categories. Définition et classification des catégories d'engins de pêches. Definición y clasificación de las diversas categorías de artes de pesca*. FAO Fisheries Technical Paper / FAO Document technique sur le pêches / FAO Documento Técnico de Pesca No. 222 Rev. 1. Rome/Roma, FAO. 92 pp. (also available at <http://www.fao.org/docrep/008/t0367t/t0367t00.htm>).
- Noel, H.S. & Ben-Yami, M.** 1980. *Pair trawling with small boats*. FAO Training Ser. 1. UK, Fishing News Books Ltd. (in English, French and Spanish)
- Prado, J.** 1991. *Guide for essential field observations concerning fishing gear and vessels in small-scale fisheries. Report of the Expert Consultation on the Marking of Fishing Gear, Victoria, British Colombia, 14–19 July 1991*. FAO Fisheries Circular No. 845. Rome, FAO. (in English and French) (Not available)
- Prado, J. & Drew, S.** 1991. *Trials and developments in fishing with handlines carried out by FAO during 1977–1989*. FAO Fisheries Circular No. 838. Rome, FAO.
- Rosman, I.** 1980. *Fishing with bottom gillnets*. FAO Training Ser. 3. Rome, FAO. 39 pp. (in English, French and Spanish)
- Von Brandt, A.** 1984. *Fish catching methods of the world*. Third edition. London, Fishing News Books Ltd.

Annex 3

Landing sites, harbours and anchorages

A3.1 INTRODUCTION

Fisheries landing sites, harbours and anchorages are key elements of the sector and play an important role in the landing, handling, marketing and processing of fish. They are also focal points of the community and can act as meeting places for groups.

The definition of landing site types will vary depending on the country (Box A3.1). Where possible, local definitions should be used (but defined as below).

BOX A3.1

Definition of landing facilities

A **landing site** or centre covers a certain physical area; the infrastructure in place; technical, financial, social services available.

The location of fisheries landing sites makes them particularly vulnerable to damage during cyclones. However, their infrastructure is also vulnerable to tsunamis and earthquakes. Rapid rehabilitation of these facilities is critical in the re-establishment of fisheries production and distribution (and marketing chains). Re-establishment of fish processing and marketing is critical in food security considerations for affected populations.

Landing facilities for fish consist of shore-based structures and marine structures (FAO, 2005). They may include:

Land-based structures

- fish auction area/hall
- fish processing facilities
- packing and storing facilities
- WC and washroom (larger sites)
- ice plant and ice store (larger facilities)
- fish waste treatment area (larger facilities)
- fuel storage area
- fresh water supply/storage area
- fishers meeting area
- fishers storage area (for equipment, engines, etc.)

- net mending area
- government office (management office)
- radio room
- battery charging area
- land area of total site and buildings
- electricity supply (mains or generator)
- boat repair facilities

Marine structures

- quay
- slipway
- breakwaters
- groynes

Together with understanding the construction, type of material and size of the structures, the disaster needs assessment teams will need to consider a range of social and management factors. These include:

- number and type of vessels using the facilities (seasonality of catches);
- management arrangements, ownership and jurisdiction;
- community groups and cooperatives their roles and functions (including non-fishers);
- fish processing (whether for export or local markets, as this will affect handling areas);
- fishers' credit and finance arrangements (these can be linked to landing facilities).

A3.2 DAMAGE ASSESSMENT

The initial impact appraisal concerning the fisheries landing facilities should be carried out by visits. If this is not possible, then interviews with key informants such as district or provincial fisheries officers may be the only source of information in initial assessments. Follow-up and detailed assessments should be carried out as soon as practically possible.

Key components of this assessment include:

1. Visit key government and/or sector officials for a rapid overview.
2. Describe types of landing sites.
3. Visit representative sites if possible to validate descriptions.
4. Teams visit all sites to record damage.
5. Summarize and report findings (stress difference between estimate and known).
6. Follow-up assessment if required.

Teams should remember that:

- Where possible, GPS should be used to determine specific locations of the landing areas.
- Where possible, a photograph should be taken of the facilities.

A3.2.1 Example of record sheets

Tables A3.1–A3.4 provide examples of recording sheets.

TABLE A3.1
Example of local classification of landing sites

Landing site types (local name)	Local method of classification used	Comment
1. Type 1	Number and type of boats Shore facilities and type Marine structures and type	
2. Type 2	Number and type of boats Shore facilities and type Marine structures and type	
3.		

TABLE A3.2
Damage assessment for individual landing sites

Site details	Province	District	Subdistrict.
Site name	Site type	Boats using site	number
Map ref/GPS	Date of visit:	Boat 1	
Reference number :		Boat 2	
		Boat 3	
		Boat 4	
Structures	Before (and units)	damage (estimate)	need
Fish auction area/hall			
Fish processing facilities			
Packing and storing facilities			
WC and washroom			
Ice plant and ice store			
Fish waste treatment area			
Fuel storage area			
Freshwater supply/storage area			
Fishers meeting area			
Net mending area			

(cont.)

Fishers storage area (for equipment, engines, etc.)			
Government office (management office)			
Radio room			
Battery charging area			
Land area of total site and buildings			
Electricity supply (mains or generator)			
Boat repair facilities			
Quay			
Slipway			
Breakwaters			
Groynes			
Number and type of vessels using the facilities (seasonality of catches)			
Management arrangements, ownership and jurisdiction			
Community groups and cooperatives their roles and functions (including non- fishers)			
Fish processing (whether for export/local markets as this will affect handling areas)			
Fishers credit and finance arrangements (these can be linked)			
....			

TABLE A3.3

Summary damage and needs assessment of landing sites by type

Landing site number	District	Province	GPS	Type	No. of boats	Before	Damage	Cost of rehab.	Before	Damage	Cost of rehab.
						Shore facilities	Shore facilities		Marine structures	Marine structures	
No. 1	District A	Province B	.../...	Type 1		\$	\$	\$	\$	\$	\$
No. 2											
Total											

TABLE A3.4

Summary estimate of rehabilitation needs

Total rehabilitation	Number damaged	Rehabilitation cost
Type 1		US\$
Type 2		US\$

A3.2.2 Key background reading

Sciortino, J.A. 1995. *Construction and maintenance of artisanal fishing harbours and village landings*. FAO Training Series No. 25. Rome, FAO. 137 pp. (also available at www.fao.org/docrep/v5270e/v5270e00.htm).

Sigurdarson, S. 2005. *Rehabilitation and reconstruction of fishing ports and fish-landing sites in Aceh Province after the tsunami. Indonesia. Mission report, 13 February – 13 March* [online]. Rome, FAO. [Cited 20 May 2013]. ftp://ftp.fao.org/fi/document/tsunamis_05/indonesia/cons_miss_rep/Sigurdur_Mar_05.pdf

Sigurdarson, S. & Wickramasooriya, N. 2005. *Master plan for the reconstruction and development of anchorages and fish landing centres along the coast of Sri Lanka* [online]. Fisheries Tsunami Emergency Programme, Sri Lanka. Rome, FAO. [Cited 20 May 2013]. ftp://ftp.fao.org/Fi/DOCUMENT/tsunamis_05/sri_lanka/cons_miss_rep/Sigurdarson_FinalDec05.pdf

Verstralen, K.M., Lenselink, N.M., Ramirez, R., Wilkie, M. & Johnson, J.P. 2004.
Participatory landing site development for artisanal fisheries livelihoods. Users' manual. FAO Fisheries Technical Paper No. 466. Rome, FAO. 128 pp. (also available at www.fao.org/docrep/007/y5552e/y5552e00.htm).

Annex 4

Aquaculture

A4.1 INTRODUCTION

The aim of the emergency needs assessment is to understand what (if any) intervention can assist in restoring aquaculture production in such a way as to profit the most vulnerable and, where possible, simultaneously reduce vulnerability and/or increase the self-reliance of the affected group. Those conducting the assessment should bear in mind that the raising of fish through aquaculture requires a period of vegetal growth, such as in agriculture, as well as experience and acquired skills.

A4.2 OVERVIEW OF THE DAMAGE ASSESSMENT

A4.2.1 Baseline data collection

Much of this work should be done as a part of the process of building an aquaculture baseline in the work to increase a nation's levels of disaster preparedness. Baseline and background data on the aquaculture sector that are relevant for disaster management purposes are listed below:

- population of the area;
- village/settlement details;
- sector details:
 - geographic location of aquaculture establishments by type,
 - area under aquaculture by type,
 - species under culture by type of aquaculture,
 - production trends by type of aquaculture and species,
 - abandoned and non-operational aquaculture establishments (this information is useful as there is a danger that non-operational and abandoned aquaculture establishments could all be compensated),
 - processing plants,
 - aquaculture community (households and total dependants/persons) directly and indirectly dependent on aquaculture, income per unit area/household by type of aquaculture, labour wages,
 - equipment: types of equipment used and cost;
- critical inputs: water sources by type of aquaculture, seed supply sources, feed supply sources, fertilizer supply sources;
- infrastructure: power supply, transportation, communication;
- human resources: useful persons/institutions during emergency phase (local authorities, farmer associations/groups, NGOs active in the field in aquaculture, researchers/scientists engaged in research work).

A4.2.2 Survey and data collection

Collection of data to assess the damage and losses is intended to quantify the consequences of the disaster, and to provide a first attempt at identifying immediate and medium-term recovery or rebuilding needs. Data and information collected should be relevant to form the basis to arrive at decisions on relief and recovery needs. Data collection should be rapid, and key problems should be checked thoroughly. Visual inspections, sample surveys, interviews with key informants (e.g. village leaders, farmer associations/groups), semi-structured interviews, and/or detailed critical sector assessments by specialists may be employed for data collection. Sources of information should be identified and indicated as this will be useful to those who interpret data. Some useful sources of information are:

- local or regional fisheries and environmental authorities;
- community leaders and village heads;
- farmers associations, management groups and/or self-help groups;
- NGOs active in the area;
- UN Agencies;
- fisheries and aquaculture researchers engaged in their research in the area;
- police and other security personnel in the affected area;
- satellite imagery;
- aerial photographs.

The information required to assess the disaster situation includes:

- nature of disaster;
- geographic area affected;
- number of aquaculture establishments affected, by type of aquaculture;
- structural damage: condition and value of the affected structures of aquaculture establishments;
- equipment damage: lost and damaged equipment being used in the aquaculture establishment;
- production damage: loss of crop in terms of quantity and value;
- loss of livelihoods: number of households/families and number of persons directly and indirectly dependent on aquaculture, number of persons' lost production, number of persons' lost wages;
- damage to infrastructure facilities to aquaculture: power supply, transportation and communication;
- damage to critical input sources such as seed, feed, fertilizer and interruptions caused to supply channels;
- secondary impacts of the disaster such as contamination, pollution and sedimentation of water sources;
- information on survival and/or adaptation strategies (savings, land, other livestock not affected by the disaster) and alternative livelihoods used before the disaster, and how have these been affected.

- information on local response capacity (credit facility, organization of farmers, service providers such as pond repair contractors, organize critical input supply from non-affected areas), government development plans and strategies and what other organizations are doing.

A4.2.3 Analysis and interpretation of data and information

Analysis and interpretation of data should focus on linking to action programmes and to recognizing trends and indicators of the existing problem. Analysis and interpretation of data to understand the following may help to identify immediate and medium-term recovery needs:

- level of damage to physical assets, i.e. which will have to be repaired/rehabilitated or restored/replaced or discounted in the future;
- income flows that will not be realized until the asset is repaired or rebuilt;
- losses may be estimated by valuing the average production that could have been achieved had the disaster not occurred or the value of wages lost by workers/employees.

A4.2.4 Reporting

Information, trends, indicators and results of the analysis should be disseminated in a format (suggested formats for flash report, initial report and detail report are given at the end of this annex) that enables disaster managers and decision-makers to design and implement action programmes.

Reporting of precise figures is not essential in flash or initial reports. The purpose of an initial report is to inform the recipient as to the severity of the disaster and to relate it to coping capacities and information needed to start mobilizing resources to help. Detail reports will provide more precise information to focus on needs for rehabilitation and reconstruction.

Assessment and reporting should be regarded as a continuous process of re-evaluating the needs and appropriateness of response and recovery interventions at regular intervals.

A4.3 TECHNICAL SPECIFICATIONS FOR DAMAGE NEEDS ASSESSMENT: AQUACULTURE

Needs assessments should be carried out to identify emergency needs in the short term as well as in the long-term rehabilitation. In the short-term scenario, the needs have to be identified to provide emergency assistance to those affected and to act as quickly as possible to recommence income-generating activities to re-establish livelihoods. Technical specifications are required to assess, quantify and value the damage as well as to fulfil requirements of the recovery, rehabilitation and reconstruction process.

This section sets out the key considerations for assessing damage and needs across a wide range of aquaculture production systems and processes.

A4.3.1 Land-based systems

A4.3.1.1 Earthen pond-based aquaculture systems

a) Structural damage:

- **Dykes:** Teams should consider first the type of dykes:
- **Perimeter dyke:** The outermost dyke that surrounds the ponds from all sides.
- **Secondary and tertiary dykes:** The partition dykes that separate the grow-out pond and nursery-pond compartments, respectively.

The following are also key assessment considerations: area of the pond (usually, dykes occupy 15–20 percent of the pond area); type of any lined material; approximate length; height and top width of the dyke (Figure A3.1); totally destroyed; partially destroyed; weakening (signs of cracks).

FIGURE A3.1 Calculation of volume of earth in a dyke

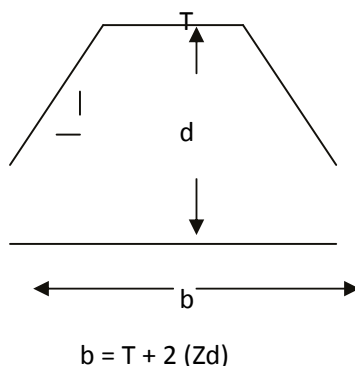

Where: b = width of base; T = width of top width or crown; d = height of dyke; z = horizontal value of side slope.

Cross section of the dyke (A) = $\{(b + T)/2\} \times d$

Volume of dyke (V) = $A \times L$ (length of the dyke)

When calculating the volume of earth in a dyke, a shrinkage allowance of usually 20 percent has to be added to the height.

- **Supply and drainage canals:** Type of any lined material of earthen canals, length, width and height of side slopes of the canal, totally destroyed, partially destroyed, accumulated sediments and debris, enclosed pipes (material, inner diameter, thickness and length).
- **Main supply canal:** Connects the farm with the water source and main drainage canal, which takes effluent/discharge water away from the farm, usually made of soil material.
- **Secondary and tertiary supply canals:** Run along the top width of secondary and tertiary dykes and usually have a concrete lining. Sometimes, these canals can be made of fibreglass or may be pipes run along the top width of dykes.

- **Culverts and pipes:** Wooden or concrete, dimensions of the conduit section (circular or square) and wing walls (if any). These structures convey water across dykes, roads on the farm, and similar embankments.
- **Inlet structures:** Lined canals associated with pipes or weir system.
- **Outlet structures:** Wooden or concrete sluice gates with wooden plank or steel plate sluices, pipes (standpipes), sluice gates associated with standpipes.
- **Pump installation structure:** Materials used and dimensions.
- **Head and sump tanks:** Materials used, capacity.

b) Equipment damage:

- **Water pumps**
 - Type of water pump: centrifugal, deep-well turbine pump, propeller pump (radial-flow, mixed-flow or axial-flow).
 - Water pump specifications: capacity of the pump in terms of discharge rate or capacity (cubic metres or litres per unit time), kilowatts or horsepower, total dynamic head (the vertical distance from the surface of water source to point of discharge), source of power (diesel, petrol, electrically driven).
- **Aerators**
 - Types of aerators: paddle wheel, pump-sprayer aerators, vertical pump aerator, diffuser or bubbler, injector type aerator or ARO2.
 - Capacity: horsepower or kilowatts.
 - Air blowers/air compressors: electric/fuel driven (oil free), motor power (kilowatt), output capacity (litres/unit time), operating pressure (bars), voltage, frequency (Hz).
- **Generator:** Capacity (kilowatts or KVA), electrical phase (two- or three-phase), rated voltage, frequency (Hz), engine (rpm), fuel (diesel, petrol), running time efficiency, with or without self-start facility.

A4.3.1.2 Land-based hatcheries

a) Structural damage

- **Damage to building structure:** Roof, walls window and doors, floor and foundation.
- **Broodstock holding ponds** (see earthen ponds): Sometimes, same ponds or part of the pond is used as breeding, hatching as well as larval rearing facility.
- **Breeding tanks** (facility to hold ready to spawn fish for spawning and fertilization of eggs): Shape (circular, rectangular, etc.), colour and dimensions or volume and number of tanks.
 - Material (cement/concrete, fibreglass, plastic, etc.).
- **Incubators or hatching facility** (to incubate fertilized eggs until hatching).
 - Double-walled hatching cloth hapas installed in still-water ponds (dimensions and number of hapas) or indoor jars/tanks.
 - Shape (cylindrical contour to a funnel, conical, barrel, circular, rectangular, etc.), colour and dimensions or volume and number of jars/tanks.

- Material of jars/tanks (clear glass, clear plastic, translucent polyethylene, canvas material, fibreglass, circular or rectangular cement tanks. etc.)
- **Larval rearing facility** (if the breeding tank is not to be used as a hatching tank and for further rearing as a larvae rearing tank, then the eggs have to be transferred from breeding tank to the hatching jars/tanks, and after hatching hatchlings have to be transferred to larvae rearing tanks).
 - Shape (circular, rectangular, etc.), colour and dimensions or volume and number of tanks.
 - Material/type of tanks (cement/concrete, fibreglass, plastic, etc.).
 - Hapas installed in ponds or waterbody (hapa dimensions and number).
- **Fry nursing:** Type of fry nursing facility.
 - Earthen ponds (see land-based earthen pond system), hapas/net cages (see also cages in section A3.2.1) submerged in open water or pond.
 - Hapa/net cages (see also cages in section A3.2.1) dimensions, material and number.
- **Live food rearing facility**
 - Type of facility: indoor and/or outdoor live food rearing facility.
 - Indoor facility for algal culture:
 - types of algal stock culture maintenance vessels – test tubes (volume), flasks to carboys (volume);
 - material type of stock culture vessels – borosilicate glass, polycarbonate, PET, etc.;
 - type and dimensions of shelves or racks to hold stock culture vessels;
 - illumination system – fluorescent lighting (number of tubes and wattage);
 - aeration system (see aeration system under equipment damage);
 - carbon dioxide source;
 - types of algal mass culture vessels – PE bags (volume), tanks (dimensions or volume);
 - framework to hold mass culture vessels;
 - filtration system (see types of filter system under equipment damage);
 - disinfection/sterilization – chlorine sterilization, autoclave, wet vapour sterilization, dry vapour sterilization, UV sterilization (also see disinfection equipment under equipment damage).
 - Outdoor facility for algal culture:
 - culture tanks – fibreglass, PE, PVC-lined concrete;
 - shape of culture tanks – cylindroconical (circular tank with conical bottom);
 - Aeration system (see aeration system under equipment damage).
- **Pipes, connectors and joints**
 - Material type of pipes (PVC) inner diameter of pipes, thickness and length.
 - Types of joints and connectors and their diameters/dimensions.

- **Quarantine facility**
 - Quarantine tanks – shape, size, material (cement, concrete, fibreglass, glass aquaria).
 - Aeration system (see aeration system under equipment damage);
- b) Equipment damage**
 - **Pumps** (see equipment damage in land-based earthen pond system).
 - **Types of filters**
 - Mechanical filters:
 - stationary screens, rotary screens, vibratory screens, sand filters, diatomaceous earth filters), chemical filters (activated carbon filters – batch type carbon filters or continuous flow carbon filters, ion-exchange filters, foam fractionation), biofilters;
 - type of material;
 - material type of screens and filter material and filtration rate or discharge rate (litres or cubic metres per unit time) in mechanical filters, material used in biofilters.
 - Cartridge filters:
 - screen material and mesh size, capacity and discharge rate.
 - **Disinfection equipment**
 - Types of disinfection:
 - UV sterilization (suspended or submerged), ozone sterilization:
 - specifications of UV sterilization – wave length, discharge rate in litres or cubic metres per unit time, type of UV sterilizer (high-pressure or low-pressure mercury lamps) and number of UV bulbs/lamps;
 - ozone generator:
 - specifications of ozone generator – discharge rate, power requirement.
 - **Heat exchangers**
 - Types of heat exchangers: heat transfer panels/plates, immersion coils and tubes, bayonet and coil or plate).
 - Specifications: heat transfer area, voltage.
 - **Aeration system**
 - Air blowers/air compressors;
 - Specifications: electric/fuel-driven (oil free), motor power (kilowatt), output capacity (litres/unit time), operating pressure (bars), voltage, frequency (Hz);
 - Air distribution pipes and tubing – material type, inner diameter and thickness, connectors and joint types.
 - **Generator**
 - Capacity (see equipment damage in land-based earthen pond system).
 - **Laboratory small equipment**
 - Water-quality testing equipment (pH meters, dissolved oxygen meters, refractometers for salinity measurement), microscopes, electronic chemical balances, etc.

A4.3.1.3 Tanks

Tanks essentially act as ponds but are generally constructed of concrete or fibreglass.

- Dimensions and capacity.
- Material used: concrete, fibreglass, wood coated with fibreglass or epoxy paint, and polyethylene, vinyl or neoprene rubber liners inside a support structure such as coated steel, aluminium or wood.
- Shape: circular, rectangular. Variations of circular tanks are silos, which are very deep, and octagonal tanks.
- Drain design: centre drains are required in circular tanks for effective removal of solid waste. Water level is controlled by an overflow standpipe placed directly in the centre drain or in the drain line outside the tank. When an external standpipe is used, the drain line must be screened to prevent fish from escaping.
- Aeration system (see aeration system under equipment damage in land-based hatcheries).

A4.3.1.4 Raceways

Fish culture in flow-through systems is a type of intensive culture where the fish are stocked densely in a long and narrow pond or tank in which there is an abundant continuous water flow (raceway). The fish are stocked in these ponds or tanks on the basis of the volume of inflowing water. They are fed a formulated pelleted food and, usually, this is their only source of nutrition. A continuous water flow ensures the proper oxygen supply to the fish and flushes away the metabolic wastes.

- Type of raceway: indoor, outdoor.
- Dimensions: width, length and water depth.
- Material used in raceway tank construction: usually rectangular reinforced concrete; large outdoor raceways can be made of earth with plastic covered inner surface; smaller indoor raceways can be built out of concrete, plastic, metal, fibreglass or wood.
- Water control structure: the tanks should be equipped with properly designed water control structures and a safety device that gives an alarm signal when the water flow (or the water level) decreases below a certain value.
- Equipment: types of emergency aerators used and capacity, automatic feeders, self-moving food dispensers, demand feeders. (In flow-through systems, intensive feeding is based on complete pelleted food that should be given to the fish regularly and in proper doses. This can be ensured by different automatic feeders first of all, but self-moving food dispensers or demand feeders can also be used.)

A4.3.1.5 Integrated irrigated/livestock aquaculture systems

- Affected aquaculture area integrated with paddy fields and other livestock.
- Structural damage (see earthen pond-based aquaculture system).

A4.3.1.6 Aquarium fish culture

- **Broodstock and breeding tanks**
 - Dimensions, volume, material type (cement, fibreglass, glass aquaria), type of water control structure (simple pipe outlet, standpipe outlet). If earthen ponds are used, see earthen pond-based aquaculture system.
- **Larval and fry rearing tanks** (same as above).
- **Grow-out tanks** (same as above).
- **Quarantine tanks** (same as above).
- **Head tanks**
 - Dimensions, volume material type (concrete, fibreglass, plastic).
- **Filtration system** (see equipment damage under land-based hatcheries).
- **Aeration system** (see equipment damage under land-based hatcheries).
- **Packing facility**
 - Type of holding/conditioning tanks: usually glass aquaria.
 - Packing equipment: oxygen cylinders, polythene sealer, insulation boxes.
- **Small laboratory equipment** (see equipment damage under land-based hatcheries).

A4.3.2 Open-water fish farming systems

- **Cages:** Cage culture is an aquaculture production system where fish are held in floating or submerged enclosures in a waterbody.
 - Cage type: fixed cages placed on the bottom substrate of waterbody, submerged cages or floating cages.
 - Sizes and number of cages and size.
 - Cage frame: bamboo, wood (type of wood), PVC pipe, high-density polyethylene (HPDE), galvanized iron pipes, aluminium.
 - Cage collar and work platform: bamboo, wood (type of wood), PVC pipe, HPDE, galvanized iron pipes, aluminium.
 - Enclosure: flexible net material, rigid mesh material:
 - flexible net material: PA (polyamide), PES (polyester), PE (polyethylene), PP (polypropylene), nylon, bamboo screens;
 - type of netting – knotted, knotless;
 - mesh size;
 - rigid mesh material: type of material – rigid polymer mesh material, metal mesh material (name the type of metal), galvanized steel weldmesh or chain-link netting, plastic-coated galvanized chain link or weldmesh.
 - Floating system: bamboo and wooden platforms also act as floating system, expanded polystyrene (record volume or dimensions), plastic or steel drums (record volume or dimensions).
 - Mooring system:
 - multiple or single point mooring;
 - components of mooring system;

- rope (PA, PES, PP, PE, braided nylon, braided PES, rope in combination with stainless steel chain), anchor (naval/marine iron anchor, cement or concrete blocks, bag of sand or pebbles, special cement anchor, iron rod).
- **Pens:** A pen is defined as a fixed enclosure in which the bottom is the bed of the waterbody. The enclosure is embedded into the bed of the waterbody by using sinkers and held under the water and above water level by a framework. A pen is to be distinguished from a cage, which in turn is defined as an enclosure with bottom and sides with an enclosure material supported by a frame, whether floating at the surface or totally submerged. The word “pen” has been used synonymous with “enclosure” as it is used in enclosure culture.
 - Dimension of the pen or enclosed water area (hectares).
 - Framework of the pen.
 - Material type: diameter and length of bamboo poles, diameter and length of wooden poles, scaffolding framework, diameter and length of steel bars.
 - Enclosure.
 - Material type: see enclosure under cage section.
 - Head and bottom rope (the head rope is the rope attached to the top of the enclosure which supports the enclosure to be held above water level, and the bottom rope is attached to the bottom of the enclosure and sinkers are attached to the bottom rope to facilitate embedding the enclosure into the bed of waterbody).
 - Material used for head and bottom rope (PA, PES, PP, PE, kurulone).
 - Diameter of head and bottom rope.
 - Sinkers to embed the net: cement or concrete blocks, etc.
- **Longline culture:** Longline culture is a modification of raft culture. This method is used for offshore culture and for mollusc culture. A rope is stretched horizontally near the water surface and kept above the surface with floats. Molluscs are grown on vertical ropes known as “droppers”, which hang from the horizontal rope. The longline is secured at each end with two anchors.
 - Length of one longline and number of lines.
 - Type of float used and number per line and volume or dimensions of floats.
 - Styrofoam, wooden barrels, metal drums (see also types of floats under section on cages).
 - Type of anchor (see anchors under section on cages)
 - Material type of rope and diameter in millimetres – polyurethane (see also ropes used under section on cages).
- **Rack culture:** Raft culture utilizes similar principles to longline culture in that the molluscs are suspended on droppers but these are suspended from the raft instead of the long lines. The rack method is a shallow-water

adaptation of the hanging culture method. To construct a rack, wooden poles are driven into the bottom, 2–4 m apart. These uprights are connected by horizontal poles. The horizontal poles support the suspended strings of cultch, which are placed at regular intervals.

- Dimensions of rack.
- Material used in rack construction – wooden poles.
- Ropes used as droppers.
- **Substrate culture:** Mud flats with clay or silty clay substrates bordering mangrove forests in shallow bays sheltered from strong wind and wave action are used to culture cockles (molluscs).
 - Estimate the area affected.
- **Pole culture:** Intertidal pole culture, also known as the bouchot technique. In this method, ropes with spat (young mussels) attached are wound around large vertical poles (bouchots) in the intertidal zone. A mesh netting is used to cover the mussels to prevent them from being detached and lost. A barrier is placed at the bottom of the pole to prevent predators such as crabs from reaching the mussels. This method of culture requires large tidal ranges in order to supply the densely packed mussels with food.
 - Estimate the number of poles affected.

A4.3.3 Production damage

Partial loss or complete loss of production by type of species and by type of culture system.

A4.3.3.1 Damage to critical input sources and interruptions caused to supply channels

Production loss of fish seed (fry and fingerlings) by type of species (tilapia, carp, catfish, shrimp by species, etc.) owing to non-operational status of hatcheries and fry-nursing establishments (rearing of fish fry to fingerlings in earthen ponds, cages, pens and tanks) and/or owing to loss of broodstock and non-availability of broodfish due to disaster situation (average number and size/weight of broodfish by type lost or required).

Amount of shortage or non-availability of fish feeds (by type – shrimp feed, fish feed. etc.) owing to non-operational status of feed manufacturing installations or feed supply centres.

Amount of shortage or non-availability of fertilizers (by type – lime, urea, super phosphate, etc.) owing to non-operational status of fertilizer supplying centres.

A4.3.3.2 Damage to water source

Type of water source, emerging or continuing threats owing to possible contamination or pollution or sediment loading.

A4.3.3.3 Loss of livelihoods

Number of households or persons with lost income flows owing to complete loss of production or lost wages and which will not be restored until the assets are repaired or rebuilt.

A4.3.3.4 Damages to infrastructure facilities to aquaculture

Loss of power supply from the national grid, interrupted or non-operational transport services and communication services, shortage or non-availability of ice owing to non-operational status of ice plants.

A4.4 RECOMMENDATIONS IN AQUACULTURE

- Identify local suppliers of fry/fingerling producers in non-affected areas at competitive commercial prices that have the production capacity to supply to affected areas, as it may take a several months to start producing fry/fingerling in the affected areas.
- It may be necessary to help the critical production input suppliers (such as feed producers/suppliers, fertilizer producers/suppliers) and other service providers (such as ice manufacturers) in parallel with production farmers as their inputs are necessary to help the farming operations.
- In compensating for broodstock shortages and losses due to disaster, importation of broodstock should be discouraged without a prior risk assessment.
- Explore possibilities to arrange soft loans or external support to meet identified common needs such as critical input supply (e.g. fish/shrimp seed, fertilizer, feed) and repair and replacements of essential equipment such as pumps, aerators and filters.
- Explore possibilities to arrange soft loans for aquaculture farmers to recommence operations.
- Provide support to fish farmers who have the opportunity and willingness to engage in small-scale or subsistence capture fishery activities until they re-start and harvest from aquaculture production systems they owned, as it may take several months for aquaculture production to be restored.
- Temporary wage earning opportunities should be explored through employment-generation programmes and schemes to generate household income. Priority should be given to those affected with no alternate livelihood opportunities and who need several months to restore their aquaculture activities.
- The initial emergency and short-term interventions for providing direct support to those who have lost or sustained damage to their production should focus on the restoration of livelihoods through the provision of production assets and means of income generation.
- Priority should be given to repairing or replacing physical assets of small aquaculture systems such as rafts, racks and small cages so that they can recommence production activities.

- Damage assessment and recovery needs may be prepared separately based on the intensity of operation. For more input-intensive aquaculture (such as coastal shrimp aquaculture), assessments may be prepared separately from less input-intensive or small-scale or more subsistence aquaculture (such as bivalve/mollusc raft/rack/substrate aquaculture, and small-scale cage aquaculture) as input-intensive aquaculture would require a specific support policy for recovery.

A4.5 SUGGESTED FORMAT FOR DETAILED ASSESSMENT

This section provides the technical background information necessary to determine what information to collect in the needs assessment in aquaculture. It also provides a basis for assistance. It is to be used in conjunction with the previous section.

Type of waterbodies:

- Freshwater.
- Brackish water.
- Marine.

System/management

- Backyard, community, extensive, semi-extensive, intensive, semi-intensive.
- Tanks, pond, cage, raceways, paddies, ditches, integrated agriculture-aquaculture (e.g. VAC system – garden/pond/livestock pen; animal–fish, e.g., fish–duck, chicken–fish, fish–pig; rice–fish, rice–prawn).
- All-in, all-out, seasonal.
- Size and number of units (e.g. size of ponds in hectares or cubic metres, cage in cubic metres).

Species

- Local name/English name (scientific name if possible).
- Origin
- Monoculture, polyculture, integrated agriculture–aquaculture farming.

Phase of operation

- Hatchery.
- Nursery.
- Grow-out.

Nutrition

- Feed (alive, manufactured, own farm, etc.).
- Feed composition: floating or sinking pallets.
- Source.
- Feeding practice.
- Price.
- Local availability.

Fingerlings

- Prices.
- Local availability.
- Health conditions.

- Stocking density of fingerlings/fry prior to shock (fingerlings per cubic metre).
- What is the grow-out season? Length of season? Starting date?
- Size of fingerlings generally stocked (grams or centimetres) and preferred stocking size.

Broodfish

- Number.
- Male/female ratio.
- Stocking density.
- Price.
- Local availability.
- Health conditions.

Fertilizers and lime

- Organic.
- Local availability.
- Price.

Material and equipment

- Equipment: pipes, nets, buckets, pumps, paddle wheels, generators, etc.
- Material of tanks: concrete, fibreglass, plastic.
- Material of cages: nylon/plastic, mesh size, floaters, poles.
- Availability of medication for fish diseases.

Market

- Size preferred by market.
- Species preferred.
- Prices of different sizes of fish at market.
- Sale alive or dead.
- Farmgate sale.
- Transport means available.
- Fluctuation of prices during year.

A4.6. FURTHER RECOMMENDATIONS IN AQUACULTURE

Provision of inputs

- It is understood that production facilities (ponds, cages, etc.) will be ready before distribution of inputs is undertaken.
- Inputs such as fingerling/fry and feed are often produced by the more well-off entrepreneurs with larger capital outlays. It may make sense to help the fingerling/fry and feed producers and the ice manufacturers in parallel to the poor farmers as their inputs are necessary to help the poorer fisherfolk.
- Identify local suppliers of fingerlings producers at competitive commercial prices.

Species

- It is generally preferred to opt for species that are traditionally grown locally. Feed requirements and the related input costs are generally lower

for traditional fish species. Besides, as these species are normally better able to cope with bad water quality, chemical and drugs requirements are much lower, so allowing more funds to be spent on fingerlings, feed or other activities.

Fingerlings

- Distributed fingerlings should preferably be slightly larger than normally purchased by the farmers as larger fingerlings seem to be less susceptible to fish diseases, adapt more rapidly to the pond environment and have lower mortality rates. Farmers generally prefer fewer fingerlings of a larger size than more fingerlings of a smaller size.
- It is recommended to use a mix of species to increase overall survival of the fingerlings.
- Verify the costs in relation to the size of the fingerlings that are to be restocked. Prices identified and typically agreed to are almost always well above actual market prices. Explanations given are various (lack of fingerlings in the market, need to transport long distances, mixed sizes of fingerlings produced by hatcheries which makes it difficult to specify one size, etc.). Sometimes, there is a 300 percent difference in price between a 3 cm fingerling and a 5 cm fingerling (typically, sizes are referred to as 3–5 cm).
- Ensure that the beneficiaries are fully informed as to the number and size of fish they are to receive.

Broodstock

- If broodstock have been destroyed during a disaster, this has a potential immediate and long-term impact on production capacity and needs to be addressed quickly. Broodfish may come, as a final option, through importation from a neighbouring country. To import brood fish, it is imperative that international standards for live aquatic species movement be used for health certification and quarantine in order to avoid potential introductions and transfers of pathogens. It is also important not to introduce/import new species. Only broodfish species that are indigenous to the country should be imported.

Transport and handling

- Distribution of fingerlings should only take place in the early morning and late afternoon when temperatures are lower in order to reduce mortality during transport.
- Advise farmers on how to release fingerlings into the water, and when.
- Use light-coloured /or white plastic bags to transport fingerlings in order to prevent penetration of sunlight and avoid warming up of water. Moreover, the suppliers should provide sufficient good-quality oxygen to the bags before transport from the point of delivery to the farms.

Feed

- A proper feed storage place is recommended.
- Beneficiaries, being poor, may have difficulty in feeding their fish sufficiently to reach marketable size in a certain period. Therefore, it is advisable to use a certain percentage of the total support costs of fingerlings, nets and feed in the form of fingerling feeds to the farmers; this to guarantee a sufficient growth rate of the fingerlings in the first period of stocking in the pond.

Quality

- Quality control before delivery should be ensured by the project in cooperation with local fisheries/aquaculture extension services.

Training

- In some cases, where it is possible (time and money) and needed, distribution of inputs and equipment should be combined with training and/or extension. Training of beneficiaries in the proper use of equipment (to be) provided (e.g. use of net and sticks to make a cover for the fish pond to reduce the chances of fish loss in case of flooding in aquaculture, etc.) constitutes an important contribution to the desired project outcomes and impact.
- In aquaculture, it is important that training on the transport of fingerlings and on pond management be conducted before fingerlings are distributed to the beneficiaries and that extension materials are provided during the training session.
- When providing nets, farmers should be trained in how to collect fish in a part of their pond or rice-field, as it would not be cost-effective to provide enough nets to farmers to circle their complete pond and/or rice field.

Beneficiaries

- It is important to identify beneficiaries in an appropriate manner. For example, a mixed community will have different needs. Separating people out according to their livelihood (fisher, fish pond owner, etc.) may miss severely affected others within a community (i.e. non-producers and landless persons). It is also important to involve local administrations in the process.

Credit

- The replacement of aquaculture inputs may be at a level too high to sustain (if the families' cash flow has also been affected) and it might contribute to the families' debt (they might borrow informally to buy feed). A slower start-up may be preferable. An area of emergency assistance that is more difficult to implement – but which may be of greater value to those affected by a disaster – is to improve access to finance in order to re-invest in affected livelihood activities.

Annex 5

Capture fisheries and aquaculture post-harvest, markets and processing

A5.1 INTRODUCTION

Post-harvest operations in the fisheries and aquaculture sector are extremely important because they provide significant employment and result in food for domestic consumption and export. Fish is a product with a high turnover rate and, unless preserved or processed, it needs to be sold and consumed within a short period.

- **Food security** and nutrition issues in emergencies (where the failure of market chains can lead to food security problems with access to fish as food) are important considerations. Fish is the main source of protein for much of the world (see: www.fao.org/focus/e/fisheries/nutr.htm). Fish also provides important nutrients and this fact should be considered when assessing the importance of market chains (see: www.fao.org/fishery/topic/2888/en). The rapid rehabilitation of fish processing and marketing can reduce dependence on post-emergency food aid and improve food security. The replacement and/or repairing of processing devices, even simple ones such as drying racks and smoking ovens, can therefore be important, and also bridge the time before more-advanced installations such as ice machines and cold stores are installed and on stream.
- The commercial-scale processing and conservation (freezing, cold chain) of fish has an **economic and financial cost**, requiring often three-phase electricity and reliable water supply and spare parts.
- **Improved processing techniques** such as dried, smoked and fermented fish products have low costs associated with the processing, and added value for customers and consumers. As a consequence, these less capital-intensive techniques can bring additional income to fisherfolk and income to fish processors (often women) and traders very quickly.
- **Fish markets** are a key infrastructure for rapidly distributing fishery products. Transport and communication with and access to local (fish) markets, fish landing centres and depots are essential to ensure a quick turnover and a fair price to fish farmers and fisherfolk.
- In post-disaster situations, post-harvest activities are often **underenumerated and undervalued**, especially if most of these are performed by women. The

importance of non-fish aquatic products should also be considered (these can be major sources of food in many countries).

A5.1.1 Chains and markets

Two key post-harvest activities are processing and marketing. In analysing of post-harvest, markets and processing damage and needs, it is important to consider the sometimes complex production and processing chains (and value chains). Understanding who is involved in the market chains is essential to ensuring recovery efforts are targeted correctly and recovery rapid.

In some cases, fisheries market chains are strongly integrated with other productions chains and markets. In theory, they can be simple or more complex (Figure A5.1). A typical seafood value chain contains elements of: **Harvesting or production from Aquaculture => Primary processing => Secondary processing => Wholesale => Retail => Consumer**

FIGURE A5.1 Aquaculture production, fisheries production, local consumption and export of shrimp

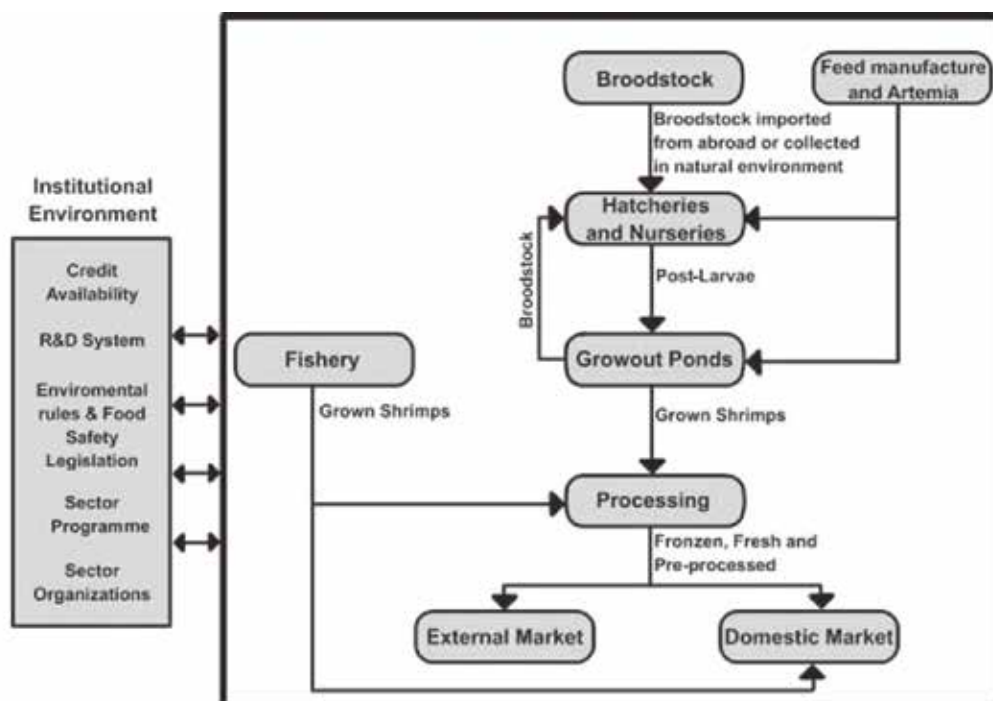

Supply chains of fish and other aquatic products are intricate and can vary according to landing, region and country. They also vary for fresh, live and processed fish products, as well as by-products such as fishmeal, chicken feed, lime and fertilizer. At some landings, buyers and/or collectors will be organized in an auction system, while others will have monopsony, monopoly

or cartel systems, or a combination thereof. In the latter systems, fishers may receive credit from buyers for fishing equipment and/or inputs. However, they are often indebted and obliged to sell to specific buyers. It is important to determine which system is in operation at landings affected by the disaster. Generally, the system that provides the best benefits for producers is the open-auction system, and post-tsunami reconstruction of supply chains needs to ensure that these systems are not lost in places where they exist.

The supply chain begins at the landing with collectors who transfer the fish to wholesalers, as well as retail-traders who buy directly. Collectors and retail traders can be categorized into those who walk, use bicycles, motorcycles, canoes, boats, vans or freezer trucks. Their assets may include baskets, weighing scales, insulation/ice boxes and vehicles. Wholesalers and distributors can be located in fishing villages affected by the disaster or in nearby towns, which may or may not be affected.

Thus, schematic representations of the supply chains of fresh and processed fish, as well as other fisheries-related products, need to be done through focus groups and key informant interviews to determine the typical patterns for a community affected by the disaster. This is necessary in order to assess the extent to which a given supply chain has been affected and to calculate losses in the various links of the chain. Post-tsunami reconstruction that focuses on delivering fishing craft and gear to producers without a careful assessment of supply chains and the steps to rehabilitate these chains will have adverse consequences for the sector as a whole.

To assess how the disaster has affected supply chains (Box A5.1), the following data are needed:

- What is the predominant form of trading at the fish landing site?
- What proportion of fishers is indebted to buyers?
- Who are the collectors/traders (gender, ethnicity)?
- Where do the collectors/traders come from (local, regional, national, international)?
- What types of equipment are used in trading?
- What types of transportation are used?
- What are the most commonly caught fish/aquatic species at the landings?
- What prices are paid for these? Are fishers paid at per kilogram, piece or string rates?
- What are the terms of trade for fishers? How do these differ during high and low seasons?

Processing

Processing is often done by women and children. It includes handling such as cleaning (washing and gutting) and salting/drying or smoking fish. Cleaning can be done at household level or often performed on piece rates in processing camps/sheds (micro/small enterprises), and the extent of this activity depends

BOX A5.1

Rapid assessment methods

“...RA methods can be convenient and cost efficient, but do require experienced personnel for the performance of the information gathering and analysis tasks. Information can be obtained by different RA methods, but in any case, before data collection starts it is strongly advisable that the following important steps are observed:

- Make an exhaustive list of the information needed, taking the performance drivers as your general guide.
- Examine all previous information already produced about the agrifood chain, including articles, research reports, documents on policy recommendations, relevant legislation, technical papers, evaluation reports, government documents, documents of representative organizations, etc. This literature can provide secondary data, information on sources of secondary data, as well as indications of organizations, companies, academic organizations, in which key informants can be found.
- Develop an info-gap matrix in which a list of the desirable information can be written in the lines, and their sources, description, products, time series length and delivery deadlines appear in the columns (see an example in Annex 4). The info-gap matrix will guide researchers on the collection of data via the RA methods.
- Identify your informants. In this regard, the so-called ‘snowball’ method, whereby informants indicate other key informants, may be used in complement to other forms of identification.
- Develop your interview guides; test them.
- Gather the information needed, organize it, analyze it, following the methods we now present...”

on seasonality. As fish is a highly perishable commodity, during the peak fishing season, processors may work long hours that are attuned to the times of fish landings. Drying or smoking fish/molluscs might be done at household level as unpaid labour or in processing camps (micro/small enterprises) for wage labour or on piece rates. If a disaster strikes during the peak fishing season, the loss of income from processing can have consequences for survival in the low season, as women are more likely to put aside savings (in the form of cash, jewellery) for lean times. Assessment needs to include asset and income losses to the number of people who are involved in processing and the length of time needed to restore their livelihoods.

Many different techniques are used to preserve fish quality and to increase their shelf-life. While these can be classified into several main approaches (below), local variations need to be described during the assessment. A significant amount of fish and aquatic product processing for local consumption and markets can take place at household or community group level. Larger-scale commercial processing can be carried out and contribute to national food supplies and exports. The main types of processing include (or are combinations of) the following:

- ice and chilling;
- drying, salting, smoking (hot/cold smoking) and freeze-drying;
- canning (techniques such as cooking, blanching, pasteurizing, sterilizing), ionizing irradiation (for pasteurization or sterilization) or microwave heating;
- fermentation, marinating or pickling, sometimes called “biopreservation”;
- vacuum packaging (sometimes with the use of CO₂, O₂ and N₂, and refrigeration).

Data collected through seasonal calendars need to cover processing:

- What proportion of fish and aquatic products (fresh, live, processed) in the community are consumed vs sold?
- Who is involved in processing – specific ethnic groups, women, men, male or female children?
- How is processing organized – household labour, wage labour or piece rate in micro/small enterprises?
- What types of fish/other aquatic species during what months – seasonality?
- What kinds of methods – cleaning, gutting, washing, drying, salting and/or smoking?
- What resources are used – utensils, equipment, buildings, water, ice, salt and/or fuel?
- To what extent have the access to these resources being affected by the disaster?

A5.2 TECHNICAL CONSIDERATIONS FOR THE DAMAGE AND NEEDS ASSESSMENT

A5.2.1 Ice and chilling (for fisheries and aquaculture)

The extent to which ice will be used in fisheries varies in developing countries. Many inland fishing systems do without ice. Ice is more likely to be available in coastal fish landings and it is an important resource for preserving the shelf life of fresh fish. It is necessary to ascertain whether ice is produced in a local plant or transported from elsewhere. Very often, a trader or group of traders will use the same freezer trucks to transport ice into the community and fish out of the community. In most developing countries, ice is used once the fish are landed; only larger vessels will use ice on board.

At a general level, the assessment (Box A5.2) will need data on:

- What is the extent to which ice is used in the community?
- Was there an ice plant in the community and what is the extent of the damage?
- Who are the traders in ice and where do they come from?
- What are the losses suffered to traders transporting ice?
- How are the ice and fish supply chains connected?
- How soon can the ice supply be restored?

- What are alternative preservation techniques/capacities available until the supply of ice can be restored?

More specific data on the use of ice should include:

- total ice production (in tonnes/day);
- types of plant : freshwater/seawater ice, flake or block ice (see: www.fao.org/docrep/003/P3407E/P3407E05.htm#4.2%20Flake%20Ice);
- water purification plants (type and capacity, power supply);
- electricity needs (mains electricity or generator, single- or three-phase, transformer size);
- plant manufacturer;
- ice costs (unit cost);
- ownership and management of the ice plant (cooperative, private, etc.).

The use of ice after its production should also be described.

- cool boxes (see: www.fao.org/DOCREP/003/P3407E/P3407E09.HTM) – these may be on vessels, in markets or for transport;
- transport of ice and fish (vehicles used, distances and costs);
- seasonality of production.

BOX A5.2

FAO post-tsunami rapid assessment, Sri Lanka

Ice is mainly supplied by two privately owned block ice plants located outside the harbour premises. However, one of the plants (Thushara Ice Plant) is out of service. The second plant (consisting of 4 block ice units and 1 flake ice unit) is located on the Galle–Matara main road and supplies all the ice necessary for the harbour. Ice is sold by these plants at LKR105/50 kg block.

A5.2.2 Drying, salting and smoking

These preservation techniques remove water from the fish flesh. They include air drying, salting, smoking, freeze-drying, the use of water-binding humectants and a combination of these. Some of these techniques, such as drying, salting and hot smoking, have been used for thousands of years. They can be implemented very simply, e.g. by salting, solar drying, or using fully automated equipment with temperature control, relative humidity, etc.

A5.2.2.1 Air drying

Simple **air drying** can be carried out by spreading the fish out on the ground. Normally, this is carried out during dry weather. Fish can be kept in the shade or in direct sunlight.

Drying racks (see: www.fao.org/docrep/005/T0606B/T0606B14.htm) and other methods to lift the fish off the ground and allow better air circulation

can be used (Figure A5.2, Plate A5.1 and Table A5.1). These also reduce the chances of contamination, etc. Further adaptations to reduce insect infestation, such as the use of polythene tunnels to cover the racks, can be made. Commercial-scale drying can be carried out using kiln or tunnel drying of fish.

FIGURE A5.2 Typical drying rack, ground drying of fish



PLATE A5.1 Fish drying on the ground and the introduction of raised drying racks, Kalemie, the Democratic Republic of the Congo, January 2009.



Source: FAO.

The assessment should provide a description of the general types of dryer used in the affected area:

- dimensions of the types of dryer used (and how they are used);
- materials used in construction (with dimensions/specifications);
- whether purchased or constructed;
- area of the dryer;
- sloped / not sloped.

A5.2.2.2 Salt

In many countries, salt (sodium chloride) is used to preserve fish (Plate A5.2). It can be used alone or in combination with smoking and drying. Salt is used to remove moisture from the fish, and sufficient quantities need to be available to processors.

The main techniques for salting fish include:

- brine, with fish placed in a solution of salt in water (usually 6–10 percent salt);
- dry salting, with dry salt is applied to the surface of the fish.

PLATE A5.2 Dried fish products, Myanmar, 2009



Source: FAO.

Combinations of these approaches may be used (Table A5.1), and local methods should be described along with the types of salt and availability. The fish may be placed in drums or containers. The type of information needed includes:

- types of local salting (species, quantities, seasonality);
- materials used for containers;
- size of containers;
- source and type of salt.

A5.2.2.3 Smoking

Smoking of fish can preserve, dry and cook fish. It is a complex process involving the controlled burning of wood, sawdust or charcoal. The type of fuels and the intensity of the fire cook and preserve the fish. Smoking processes are generally divided into:

- cold smoking, where the temperature of the flesh does not exceed 30 – 40 °C (this is used mainly in temperate climates);
- hot smoking, where the flesh of the fish is cooked.

Smoking is used in combination with salting and drying (Table A5.1) and can result in products with a long shelf-life and allow transport to distant markets. Smoking technology can vary from simple locally manufactured designs to large-scale commercial operations (Figure A5.3; see: www.fao.org/docrep/005/T0606B/T0606B14.htm).

The type of information needed includes:

- types of local smoking (species, quantities, seasonality, markets);
- materials used for smoking apparatus (purchased or home-made);
- dimensions and layout of containers;
- source and type of fuelwood used.

FIGURE A5.3 Layout of “Chorkor oven”

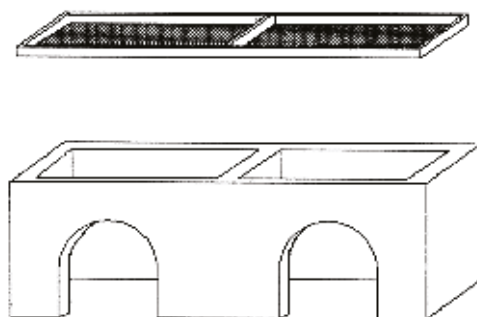

A5.2.3 Fermentation, pickling and “biopreservation”

Fermentation of fish is a common processing and preservation technique (see *Fish Handling, Preservation and Processing in the Tropics: Part 2* (NRI <http://nzdl.sadl.uleth.ca/cgi-bin/library?>)). The process breaks down larger complex materials in the fish flesh, such as proteins, into simpler stable ones. Unlike preservation techniques, the aim of fermentation is to break the flesh down to varying degrees. Sometimes, flavours or salt can be added to the process. The breakdown can be carried out by enzymes in the fish or by micro-organisms. The three main categories of product are:

- products in which the fish is converted into a liquid (fish sauce);
- products in which the fish is reduced to a paste;
- products in which the fish remains intact or mainly intact (Table A5.1).

A5.2.3.1 Fish sauce

Fish sauce production involves fermentation of small fish (or sometimes shrimp or crabs and other marine animals) to produce a liquid. The fish are fermented for longer than is required to make a fish paste. The fish are packed into a container along with salt and left to ferment. The sauces produced contain a mixture of amino acids and the products of protein degradation but have a high salt content. They are used as condiments for flavouring. To prepare the sauce, fish are first washed then placed in a barrel with salt at a ratio of from 1:5 to 1:1. The fish–salt mix is lightly compressed and left to ferment for 5–18 months. The liquid is drained from the bottom of the container and filtered before use. Different grades of product can be taken at different times, and the yield is about 90 percent of fish sauce by weight of fish (Figure A5.4).

FIGURE A5.4 Example of fish sauce production equipment

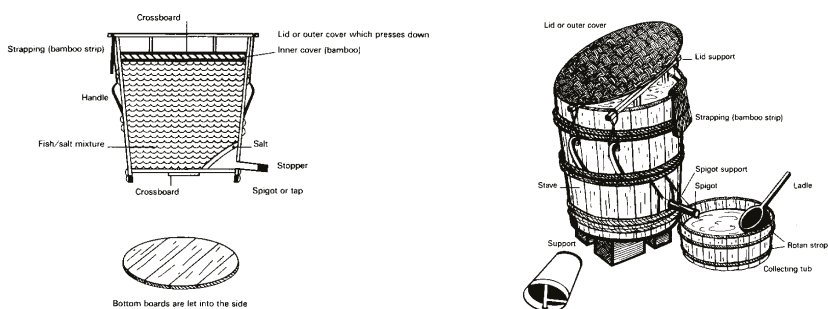

Source: Redrawn from Figure 19 in Food and Agriculture Organization of the United Nations Regional Office for Asia and the Far East, Bangkok (1987). Indo-Pacific Fisheries Council Regional Studies No. 4, Fish processing in the Indo-Pacific area, compiled by G. N. Subba Rao.

Redrawn from Figure 19 in Food and Agriculture Organization of the United Nations Regional Office for Asia and the Far East, Bangkok (1987). Indo-Pacific Fisheries Council Regional Studies No. 4, Fish processing in the Indo-Pacific area, compiled by G. N. Subba Rao.

The type of information needed includes:

- types of local fish sauce production (species, quantities, seasonality, markets);
- materials used (purchased or home-made);
- dimensions and layout of containers;
- source and type of salt used.

A5.2.3.2 Fish paste

Fish paste production in many countries can be an important household-level activity. It involves pounding fish (shrimp, crab or other aquatic animals) into a paste with salt or other flavourings (such as chillies and spices). The product can be sun dried but is left to ferment in an airtight container until the moisture content is about 35–50 percent of the original. The paste can be used domestically or sold at local markets (Plate A5.3).

The type of information needed includes:

- types of local fish paste production (species, quantities, seasonality, markets);
- materials used (purchased or home-made);
- dimensions and layout of containers;
- source and type of salt used.

PLATE A5.3 Fermented fish paste (left) and fish sauce in a local market (right), Myanmar, 2009.



Source: FAO.



TABLE A5.1

Overview of the utensils, tools and containers used in each of the processing methods, their unit price and their number required for each household, Myanmar, 2009

	Rectangular plastic fish box, 100 litre capacity	Plastic tray with perforations, 21 x 14 x 6 inches	Plastic basin with perforations, 21 (diameter) x 14 (height) inches	Plastic buckets with lids, 12 (diameter) x 8 (height) inches	Stainless steel knife for cutting, 6 x 3 inches	Stainless steel knife for heading, 6 x 2 inches	Stainless steel knife for splitting/ filleting/ scaling, 5 x 1 inch	Waterproof apron	Gloves	Head cover	Plastic boots	Plastic cutting board, 14 x 9 inches	Weighing scale with dial, up to 20 kg maximum load	Mincer, semi-industrial No. 12	Plastic basin, 19 x 11 inches
Unit cost (MMK)	52 000	6 200	4 800	2 750	2 000	1 200	600	4 000	1 250	2 200	3 000	2 500	33 000	25 000	4 800
1. Fermented fish paste and sauce (yay-kyo nga-pi)	2	6	6	6	6	6	6	6	12	6	6	6	1		
2. Fermented shrimp paste and sauce (hmyin-nga-pi and ngan-pyar-yay)	2	6		6	6			6	12	6	6	6	1	1	4
3. Salted-and-dried fish (nga-chauk)	2	6	6		6	6	6	6	12	6	6	6			4
4. Salted and dried shrimp (pazum-chauk)	2	6	6		6			6	12	8	6		1		
5. Smoked fish or shrimp (nga kyat-taik or pazun kyat-taik)	2	6			6	6	6	6	12	8	6	4	1		
6. Salted fish (nga-pi-gaung)	2		6		6	6	6	6	12	8	6	6			
7. Fish/shrimp cracker, crisps (nga-mote, pazum-mote)	1		6		6	6		6	12	8	6	6		2	
8. Fermented shrimp and fish (pazun chin / nga chin)	2	6	6	6	6			6	12	8	6	6		2	

Source: FAO.

A5.2.3.3 Canning

Canning (including techniques such as cooking, blanching, pasteurizing and sterilizing) is a relatively new technology found in many countries. The approach uses heat to sterilize the product in a sealed can to prevent bacteria from entering. Fish can be canned in water, brine or vegetable oils. Prior to canning, the fish need to be processed (removing the head, gutting, scaling, etc). Key considerations in canning are the heat transfer to the can and overall temperature during processing. Small-scale canning facilities can be found in many countries.

A5.2.3.4 Other methods

Other methods of fish processing include vacuum packaging (sometimes with the use of CO₂, O₂ and N₂ and refrigeration), freeze-drying, ionizing irradiation (for pasteurization or sterilization) or microwave heating.

A5.3 DATA COLLECTION, ANALYSIS AND SUMMARY

A summary description of the main market chains should be prepared along with a general description of the main processing techniques in the affected area (Tables A5.2–A5.5).

TABLE A5.2
General description of local fish processing

Main types of processing (local name)	Description and local method of classification used	Comment
1. Processing 1	Type of fish (and seasonality) Processing type Market chain Facilities needed and type Social factors (who does it?) Location	
2. Processing 2	Type of fish (and seasonality) Processing type Market chain Facilities needed and type Social factors (who does it?) Location	
3. etc.		

TABLE A5.3
Summary damage assessment for locality/district

Locality details	Province (name)	District (name)	Subdistrict (name)
Name			
Map ref/GPS	Date of visit		
Reference number			
Processors by type	Before (and units)	Damage (estimate)	Need
1. Ice and chilling			
Ice plant 1 (flake 10 tonnes/day)			
Ice plant 2 (block 10 tonnes/day)			
Ice traders			
Cool boxes (trader)			

(cont.)

Processors by type	Before (and units)	Damage (estimate)	Need
Cool boxes (fishers)			
Cold stores			
Refrigerated vans			
2. Drying			
Solar dryers (small-scale local consumption 10 kg/day)			
Oven dryers			
3. Salting			
4. Smoking (hot/cold smoking)			
6. Canning			
7. Fermentation			
8. Other			

TABLE A5.4
Summary damage and needs assessment processing by type

District Name	Province Name	GPS	Processing type	Units	Before	Damage	Cost of rehab.	Total
					Shore facilities	Shore facilities		
District A	Province B	.../...	Type 1		US\$	US\$	US\$	US\$
			Type 2					

TABLE A5.5

Summary estimate for emergency

Total rehabilitation	Number damaged cost	Rehabilitation cost
Type 1	US\$	US\$
Type 2	US\$	US\$

A5.4 KEY BACKGROUND READING

Da Silva, C.A. & de Souza Filho, H.M. 2007. *Guidelines for rapid appraisals of agrifood chain performance in developing countries*. Agriculture, Management, Marketing and Finance Occasional Paper No. 20. Rome, FAO. 111 pp. (also available at www.fao.org/docrep/010/a1475e/a1475e00.htm)

Gudmundsson, E., Asche, F. & Nielsen, M. 2006. *Revenue distribution through the seafood value chain*. FAO Fisheries Circular No. 1019. Rome, FAO. 42 pp. (also available at <ftp://ftp.fao.org/docrep/fao/009/a0564e/a0564e00.pdf>)

Shawyer, M. & Medina Pizzali, A.F. 2003. *The use of ice on small fishing vessels*. FAO Fisheries Technical Paper No. 436. Rome, FAO. 108 pp. (also available at www.fao.org/docrep/006/y5013e/y5013e00.htm).

Subasinghe, S. 2005. *Assessment of rehabilitation and reconstruction needs in the tsunami affected post-harvest fisheries sector – Sri Lanka*. Rome, FAO. 42 pp. (also available at ftp://ftp.fao.org/Fi/DOCUMENT/tsunamis_05/sri_lanka/cons_miss_rep/Subasinghe_Apr_05.pdf).

Subasinghe, S. 2005. *Assessment of rehabilitation and reconstruction needs in the tsunami affected post-harvest fisheries sector – Maldives*. Rome, FAO. 42 pp.

Teutscher, F. ed. 1992. *Proceedings of the symposium on post-harvest fish technology. Cairo, Egypt, 21–22 October 1990. Compte rendu du Colloque sur la technologie du poisson après capture. Le Caire, Egypte, 21–22 octobre 1990*. CIFA Technical Paper/Document technique du CPCA No. 19. Rome, FAO. 117 pp. (also available at www.fao.org/docrep/005/t0606b/t0606b00.htm).

FAO 2009 Technical Fact Sheet 19, **Traditional Fish and Shrimp Products of the Delta region of Myanmar (2009)**. [Unpublished technical document in support of Agriculture cluster].

Annex 6

Environment

A6.1 INTRODUCTION

The fisheries and aquaculture sector is highly dependent on the quality of the natural environment. Disasters can have a profound effect on that environment, which can affect both the recovery and rehabilitation of communities affected by a disaster. It is important, as part of the damage and needs assessment to understand those effects, their consequences and the need for corrective action.

Key areas of concern for environmental change in the sector include those set out below.

Fisheries

- Fish stocks: including the stocks for target species, retained species landed in conjunction with the target species, and discarded species.
- Endangered, threatened and protected (ETP) species: including those species in national or international legislation/agreements and FAO International Plans of Action.
- Habitats: these are key to supporting the fisheries, e.g. spawning and nursery grounds.
- Ecosystem: considering the broader ecological community within which the fisheries exist.

Aquaculture

- Stock species: including spat/seed.
- Feed: including the use of wild resources and feed efficiency.
- Habitats: considering the habitats that support aquaculture developments.
- Ecosystem: considering the broader ecological community and carrying capacity of aquaculture developments, including the role of environmental impact assessments (EIAs).

A6.2 POTENTIAL EFFECTS OF DISASTERS ON THE ENVIRONMENT

There are a number of effects and impacts that a disaster can have on the fisheries and aquaculture environment. These include:

- mortality of wild fish owing to pollution, habitat loss or food supplies;
- loss of fish from fish and seed farms;
- fish kills or tainting of fish flesh caused by pollutants (oil, chemicals, radioactive pollutants);
- expansion of wild stocks owing to a reduction in fishing effort caused by loss of gear or reduction in demand;

- reduced access to feed for fish farming owing to the effects on wild stocks;
- overexploitation of fish stocks owing to increased fishing effort from poorly planned rehabilitation of the fleet/gear;
- irreversible effects on stocks of ETP species;
- destruction or modification of habitats such as turtle nesting sites, coral reefs, mangrove areas, seagrass beds;
- redirection of freshwater outflows changing the ecological characteristics of wetlands;
- ghost fishing from lost fishing gear;
- habitat change owing to salt intrusion;
- pollution owing to the disposal of damaged or contaminated fish.

A6.3 KEY REQUIREMENTS FOR IDENTIFYING ENVIRONMENTAL MANAGEMENT NEEDS IN POST-DISASTER SITUATIONS

Environmental considerations are often not to the fore in management or decision-making immediately after a disaster has occurred. However, in addition to the immediate and life-saving needs of the communities affected by a disaster, there is also a need to look at how decisions for recovery and rehabilitation will affect the environment in the longer-term, and how these will affect people's livelihoods into the future.

After a disaster, environmental management needs for fisheries and aquaculture operations can be identified by undertaking an environmental needs assessment (ENA). This can be as part of a wider ENA (covering other non-fish related environmental aspects), or included within a wider fisheries and aquaculture needs assessment.

The United Nations Environment Programme (UNEP, 2008) has developed a practical guide for implementing environmental needs assessments in post-disaster situations. Three separate but inter-related phases are designed to focus attention on different levels and needs while promoting streamlined information-gathering. In relation to fisheries and aquaculture, the three phases can be summarized as set out below.

Phase I – Pre-disaster baseline

Gathering as much reliable information on the actual situation immediately before the disaster, as well as during lead-up events to the disaster, is important for understanding the baseline situation and, therefore, interpreting attribution of impacts to the disaster. Many different sources of information can be utilized. Key question areas include:

- What are the environmental profiles of key stocks, habitats and ETP species?
- What aquaculture, fisheries and wildlife management plans are in place?
- What previous environment-related assessments have been carried out?
- What specific databases, e.g. fisheries landings, aquaculture production on a national/regional scale, exist?

- What sources of local knowledge on natural resources management exist and how can they be used?

Phase II – Situation analysis and site assessment

Based on the information gathered, a risk-mapping exercise can be carried out to highlight key areas of concern or probable impact. This is preceded by targeted on-the-ground data collection, observation and verification. To assess the scale and severity of the situation, three broad approaches are recommended by UNEP (2008):

- further data gathering, which may take the form of background research and desk studies, combined with some interviews of key government and non-governmental actors in country;
- preliminary risk analysis supplemented by on-site assessments, which would include direct observations;
- stakeholder consultations with representatives of the affected community/industry.

Phase III – Stakeholder engagement and consultation

Engaging with a broad range of people – from decision-makers in line ministries to actual practitioners who have a direct dependence on certain natural resources – is a fundamental part of the ENA process. Some consultation will naturally occur during the site assessment work. However, given the importance of making sure that peoples' own voices and experiences are recorded, and their immediate (and longer-term) needs identified, special attention is given to this phase of work. Consultations are also an essential opportunity to ensure that all members of the affected society have an opportunity to contribute to the early recovery process, while at the same time ensuring that cross-cutting issues such as gender are properly addressed.

Overall, an ENA should aim to provide:

- comprehensive environmental damage assessments;
- the basis for developing environmental rehabilitation plans for affected natural resources.

In the short-to-medium term, the focus of environmental management of aquaculture and fisheries is likely to be on allowing key natural environments, such as water quality, coral reefs, mangroves and fishery resources, time to recover from the impact of the disaster. In the longer term, development of rehabilitation management plans involving all stakeholders can ensure sustainable long-term management of these resources.

A6.4 TECHNICAL SPECIFICATIONS FOR DAMAGE NEEDS ASSESSMENT: ENVIRONMENT

The sorts of information that are needed in an assessment in a disaster situation, to address environmental issues, include baseline information and information about changes that have occurred. Some key questions that will assist in implementing an environmental assessment are outlined below.

A6.4.1 Environmental status

A6.4.1.1 Marine environment baseline

- What different marine habitats exist in the area being considered (e.g. reefs, mud flats, seagrass areas, mangroves, sandy beaches, inshore areas, rocky shores)?
- How do they change seasonally?
- Where are they located?
- Which ones are the most important from a fisheries and aquaculture perspective?
- Which ones are most important to different stakeholder groups?
- Which habitats have been affected by the disaster, to what extent and over what area?
- What form has the change taken (e.g. pollution, destruction, erosion, salinity change)?
- How has the disaster affected local biodiversity, biomass and ecosystem integrity?
- What are the main fish stocks that are commercially exploited?
- What are the main fish stocks that are exploited for subsistence?
- Which species are endangered, threatened and protected species?

A6.4.1.2 Marine environment impact appraisal

- Which fish stocks have been affected by the disaster?
- How have these been affected by the disaster?
- How have endangered, threatened and protected species been affected by the disaster?

A6.4.1.3 Freshwater environment baseline

- What different freshwater habitats exist in the area being considered (e.g. lakes, rivers, streams, floodplain, flooded forest)?
- How do they change seasonally?
- Where are they located?
- Which ones are the most important from a fisheries and aquaculture perspective?
- Which ones are most important to different stakeholder groups?

A6.4.1.4 Freshwater environment impact appraisal

- Which habitats have been affected by the disaster, to what extent and over what area?
- What form has the change taken (e.g. pollution, destruction, erosion, salinity change)?
- How has the disaster affected local biodiversity, biomass and ecosystem integrity?
- What are the main fish stocks that are commercially exploited?
- What are the main fish stocks that are exploited for subsistence?
- Which species are endangered, threatened and protected species?
- Which fish stocks have been affected by the disaster?
- How have these been affected by the disaster?
- How have endangered, threatened and protected species been affected by the disaster?

A6.4.1.5 Aquaculture environment baseline

- What marine and freshwater habitats are used for fish farming?
- What are the main fish species that are commercially farmed?
- What are the main fish stocks that are farmed for subsistence?
- What is the seasonal change in these habitats?
- Where are they located?
- How are these habitats affected by aquaculture activity (e.g. water abstraction, pollution from feed or waste materials)?
- Which ones are the most important from an aquaculture perspective?
- Which ones are most important to different stakeholder groups?

A6.4.1.6 Aquaculture environment impact appraisal

- Which habitats have been affected by the disaster, to what extent and over what area?
- What form has the change taken (e.g. pollution, destruction, erosion, salinity change)?
- How has the disaster affected local biodiversity, biomass and ecosystem integrity?
- Which fish farms have been affected by the disaster?
- How have these been affected by the disaster?

A6.4.2 Environmental management:

A.4.2.1 Current environmental management systems baseline

- What current environmental management systems are in place in the marine environment?
- What current environmental management systems are in place in the freshwater environment?
- What current environmental management systems are in place in aquaculture?

A6.4.2.2 Current environmental management systems impact appraisal

- How have these been affected by the disaster?

A6.4.2.3 Environmental governance baseline

- What governance systems are in place in the marine environment?
- What governance systems are in place in the freshwater environment?
- What governance systems are in place in aquaculture?

A6.4.2.4 Environmental governance impact appraisal

- How have these been affected by the disaster?

A6.5 KEY RESOURCES

Allen, G.R. 2005. Tsunami underwater: marine effects of the S.E. Asian Tsunami at Weh Island, Indonesia. *Golden Dolphin Video CD Magazine*, 23.

CENARA. (undated). Project on Capacity Enhancement of NARA for Marine Resource Surveys and Stock Assessments in Selected Fisheries/Resources in the Coastal Waters of Sri Lanka. In: *CENARA* [online]. Colombo. [Cited 20 May 2013]. www.nara.ac.lk/cenara/aboutUs.html

FAO. 2003. *Fisheries Management. 2. The Ecosystem Approach to Fisheries*. FAO Technical Guidelines for Responsible Fisheries No. 4 Suppl. 2. Rome. 112 pp. (also available at www.fao.org/DOCREP/005/Y4470E/Y4470E00.HTM)

FAO. 2008. *Fisheries management. 3. Managing fishing capacity*. FAO Technical Guidelines for Responsible Fisheries No. 4, Suppl. 3. Rome. 104 pp. (also available at <ftp://ftp.fao.org/docrep/fao/011/i0318e/i0318e.pdf>)

FAO. 2009. *Fisheries management. 2. The ecosystem approach to fisheries. 2.2 Human dimensions of the ecosystem approach to fisheries*. FAO Technical Guidelines for Responsible Fisheries No. 4, Suppl. 2, Add. 2. Rome. 88 pp. (also available at www.fao.org/docrep/012/i1146e/i1146e00.pdf).

FAO. 2009–2013. Reduction of environmental impact from tropical shrimp trawling through the introduction of by-catch reduction technologies and change of management - Web site. ICES-FAO Working Group on Fishing Technology and Fish Behaviour. FI Institutional Websites. In: *FAO Fisheries and Aquaculture Department* [online]. Rome. Updated. [Cited 20 May 2013]. www.fao.org/fishery/topic/16921/en

FAO. 2010. *The State of the World Fisheries and Aquaculture 2010*. Rome. 197 pp. (also available at www.fao.org/docrep/013/i1820e/i1820e.pdf).

FAO. 2010. *Aquaculture development. 4. Ecosystem approach to aquaculture*. FAO Technical Guidelines for Responsible Fisheries No. 5, Suppl. 4. Rome. 53 pp. (also available at www.fao.org/docrep/013/i1750e/i1750e.pdf).

FAO. 2011. *Technical guidelines on aquaculture certification. Directives techniques relatives à la certification en aquaculture. Directrices técnicas para la certificación*

- en la acuicultura*. Rome/Roma. 122 pp. (also available at www.fao.org/docrep/015/i2296t/i2296t00.htm).
- FAO EAF-Nansen Project**. 2010. *Report of the Expert Workshop on the Development and Use of Indicators for an Ecosystem approach to fisheries*. Rome, 20–24 April 2009. FAO EAF-Nansen Project Report No 7. Rome, FAO. 57 pp. (also available at www.fao.org/docrep/014/am429e/am429e.pdf).
- Forbes, K. & Broadhead, J.** 2008. *The role of coastal forests in the mitigation of tsunami impacts*. RAP Publication 2007/1. Bangkok, FAO. 30 pp. (also available at www.fao.org/forestry/14561-09bf06569b748c827dddf4003076c480c.pdf).
- Hamiton, R., Ramohia, P., Hughes, A., Siota, C., Kere, N., Giningele, M., Kereseke, J., Taniveke, F., Tanito, N., Atu, W. & Tanavalu, L.** 2007. *Post-tsunami assessment of Zinoia Marine Conservation Area, South Choiseul, Solomon Islands*. TNC Pacific Island Countries Report No. 4/07.
- International Association for Impact Assessment (IAIA)**. 1999. *Principles of environmental impact assessment best practice*. Fargo, USA. 4 pp. (also available at www.iaia.org/publicdocuments/special-publications/Principles%20of%20IA_web.pdf).
- International Atomic Energy Agency (IAEA)**. 2005. *Environmental and source monitoring for purposes of radiation protection: safety guide*. IAEA Safety Standards Series No. RS-G-1.8. Vienna. 119 pp. (also available at www-pub.iaea.org/MTCD/publications/PDF/Pub1216_web.pdf).
- International Atomic Energy Agency (IAEA)**. 2007. Arrangements for preparedness for a nuclear or radiological emergency : safety guide. Jointly sponsored by International Atomic Energy Agency, the Pan American Health Organization, the World Health Organization, the Food and Agriculture Organization of the United Nations, the International Labour Office and the United Nations Office for the Coordination of Humanitarian Affairs. IAEA Safety Standards Series No. GS-G-2.1. Vienna. 145 pp. (also available at www-pub.iaea.org/mtcd/publications/pdf/pub1265_web.pdf).
- Jernelov, A.** 2005. The environmental effect of tsunamis. In: *Project Syndicate* [online]. [Cited 20 May 2013]. www.project-syndicate.org/commentary/the-environmental-effect-of-tsunamis
- Kapurusinghe, T.** 2005. *Affects of tsunami on marine turtles & turtle conservation efforts in Sri Lanka* [online]. [Cited 20 May 2013]. www.ioseaturtles.org/UserFiles/File/elec_lib/Sri_Lanka2.pdf
- Kelly, C.** 2005. *Guidelines for rapid environmental impact assessment in disasters*. Developed by: Benfield Hazard Research Centre, University College London and CARE International.
- Macfadyen, G., Huntington, T. & Cappell, R.** 2009. *Abandoned, lost or otherwise discarded fishing gear*. UNEP Regional Seas Reports and Studies No. 185; FAO Fisheries and Aquaculture Technical Paper, No. 523. Rome, UNEP/FAO. 115 pp. (also available at <ftp://ftp.fao.org/docrep/fao/011/i0620e/i0620e.pdf>).

- Marcus, M.B.** 2011. Gulf seafood safety concerns consumers. In: *USA Today* [online]. [Cited 20 May 2013]. <http://yourlife.usatoday.com/fitness-food/safety/story/2011/05/Gulf-seafood-safety-concerns-consumers/47507778/1>
- Peterson, C.H., Rice, S.D., Short, J.W., Esler, D., Bodkin, J.L. & Ballachey, B.E.** 2003. Long-term ecosystem response to the Exxon Valdez oil spill. *Science*, 302: 2082–2086.
- Repanich, J.** 2010. The Deepwater Horizon spill by the numbers. In: *Popular Mechanics* [online]. [Cited 20 May 2013]. www.popularmechanics.com/science/energy/coal-oil-gas/bp-oil-spill-statistics
- Rotkin-Ellman, M., Wong, K.K. & Solomon, G.M.** 2012. Seafood contamination after the BP Gulf oil spill and risks to vulnerable populations: a critique of the FDA risk assessment. *Environmental Health Perspectives*, 120(2): 157–161. (also available at <http://ehp03.niehs.nih.gov/article/info:doi%2F10.1289%2Fehp.1103695>).
- Students' Sea Turtle Conservation Network (SSTCN).** 2009. World Bank funded coastal shelterbelt project covering sea turtle nesting habitats in Tamil Nadu, India. In: *SSTCN* [online]. [Cited 20 May 2013]. <http://sstcn.org/sstcns-battle-with-the-world-bank/>
- United Nations Economic Commission for Europe (UNECE).** 2013. Convention on Environmental Impact Assessment in a Transboundary Context (Espoo, 1991). In: *UNECE* [online]. [Cited 20 May 2013]. www.unece.org/env/eia/
- United Nations Environment Programme (UNEP).** 2005. *National rapid environmental assessment – Thailand* [online]. [Cited 20 May 2013]. www.unep.org/tsunami/reports/TSUNAMI_THAILAND_LAYOUT.pdf
- United Nations Environment Programme (UNEP).** 2008. *Environmental needs assessment in post-disaster situations: a practical guide for implementation* [online]. [Cited 20 May 2013]. www.gdrc.org/uem/disasters/disenvi/pdna.pdf
- United Nations Framework Convention on Climate Change (UNFCCC).** 2013. *United Nations Framework Convention on Climate Change* [online]. [Cited 20 May 2013]. <http://unfccc.int/2860.php>
- Weiss, D.** 2011. *Contamination of water, sediments and biota of the Northern Pacific coastal area in the vicinity of the Fukushima NPP* [online]. [Cited 20 May 2013]. www.eurosafe-forum.org/userfiles/2_2_%20paper_marine%20environment_Fukushima_20111031.pdf
- Yender, R., Michel, J. & Lord, C.** 2002. *Managing seafood safety after an oil spill* [online]. Seattle, USA, Hazardous Materials Response Division, Office of Response and Restoration, National Oceanic and Atmospheric Administration. [Cited 20 May 2013]. http://docs.lib.noaa.gov/noaa_documents/NOS/ORR/963_seafood2.pdf

In the last few decades, natural disasters have become more frequent and increasingly destructive. Populations depending on fisheries and aquaculture for their livelihoods are threatened, not only by natural hazards, but also by human-induced events beyond their control. Most small-scale fishers and fish workers live in developing countries and often face multiple problems that increase their vulnerability such as pollution, environmental degradation, overexploitation of resources, high levels of accidents at sea and conflicts with industrial fishing operations. Many coastal communities are especially at risk due to poverty and food insecurity.

The particular characteristics of the fisheries sector and the livelihood context of small-scale fishers and fish farmers and their communities need to be clearly understood in order to be able to provide adequate disaster response in an emergency situation. An assessment of disaster impact is essential, not only for supporting the decision-making process before and during the immediate relief efforts, but also to set the basis for longer-term recovery planning.

These guidelines have been developed with a wide range of partners to support post disaster damage and needs assessments in the fisheries and aquaculture sector . Aimed at those people who organize or carry out such assessments, the guidelines consist of a core document, which articulates the process and reporting requirements of post-disaster needs assessments supported by technical annexes that provide specific guidance relating to different aspects of fisheries and aquaculture.

